



Assembly, installation and maintenance manual

SAN BERNARDINO Playhouse

Width 180 x Depth 190 cm
Wall thickness 16 mm



WARNINGS:

Not suitable for children under 3 years. Risk of crushing.

To be used under the direct supervision of an adult. Risk of falling.

Only for outdoor domestic use.

Keep away from fire.

The product is supplied disassembled. Adult assembly required.

Intended for children from 3 to 14 years (max 50 kg/user).

Attention!

- It is not allowed to climb on the barriers and roof of the assembled house.
- Caution. Wooden details can contain slight torn grain or sharp ends and edges.
- The product is designed for simultaneous use by up to 6 persons.
- The house must be anchored to the base surface! It is not allowed to use a house that is not anchored! You must select the anchors (not included in the supplied kit) and the appropriate method of attachment depending on the base surface (see installation manual)!
- The supplied kit does not include any roof cover material. Before you begin using the house, you must obtain a suitable roof cover material (bitumen shingles or rolls) and install it in accordance with the manufacturer's instructions! It is not recommended to leave the house without a roof cover in the rain or it will void the warranty!
- The product is delivered unfinished.

1 Assembly manual



Dear client,

We are glad that you have decided in favour of our garden house!

Please read the assembly manual carefully before proceeding with the house installation! You will thus avoid problems and will not waste time.

Recommendations:

- Keep the house package until its complete assembly in a dry place, but not in direct contact with the ground, protected from weather conditions (moisture, the sun, etc.). Do not keep the house package in a heated room!
- Begin by choosing a suitable location for the house. Make sure that there is enough space around the house both for playing and for regular inspection and maintenance of the house (recommended: at least 2 metre on all sides).
- When selecting the garden house location, make sure that the house will not be subjected to extreme weather conditions (areas of strong snowfall or winds); otherwise you should attach the house (for instance, with anchors) to the subsoil.
- Since the foundation joists are in constant contact with the ground they must be treated with a special wood preservative. Consult a specialist regarding paints suitable for unprocessed softwood and follow the paint manufacturer's instructions.



Warranty

Your house is made from high quality fir and delivered in the natural (unprocessed) form. If, despite our thorough inspection, you should have complaints, please submit the filled out control sheet and purchase invoice to the product seller.

ATTENTION: Please be sure to keep the documentation accompanying the house package! The control sheet includes the control number of the house. We can only review complaints if you submit the control number of the house to the seller!

The warranty does not cover:

- Peculiarities of wood as a natural material
- Wooden details already painted (processed with a wood preservative)
- Wooden details containing whole branches that do not endanger the stability of the house
- Colour tone variations caused by wood structure differences that do not influence wood lifetime
- Wooden details containing (caused by drying) small cracks/gaps that do not pass through and do not influence the structure of the house
- Twisted wooden details if they can nevertheless be installed
- Roof and floor boards that may have on their concealed surfaces some non-planed areas, colour differences and waning
- Complaints resulting from an incompetent manner of the installation of the house or the house subsiding due to an incompetently made foundation
- Complaints caused by introducing self-initiative changes to the house, such as the deformation of wooden details and doors/windows due to an incompetent manner of wood processing; the attachment of storm braces too rigidly, doorframes being screwed onto wall logs, etc.

The complaints covered by the warranty are satisfied to the extent of replacing the deficient/faulty material. All other demands will be excluded!



Garden house painting and maintenance

Wood is a natural material, growing and adapting depending on weather conditions. Large and small cracks, colour tone differences and changes, as well as a changing structure of wood are not errors, but a result of wood growing and a peculiarity of wood as a natural material.

Unprocessed wood becomes greyish after having been left untouched for a while, and can be turn blue and become mouldy. To protect the wooden details of your garden house, you must immediately process them with a wood preservative.

Attention! **The house is supplied without elaborative workmanship. To reduce fire hazard you should use paints or impregnation substances that prevent fire from spreading! Use water-based paints and impregnation substances and avoid solvent-based products!**

Consult a specialist regarding paints suitable for unprocessed softwood and follow the paint manufacturer's instructions.

It is not allowed to cover the product with lacquer or paint on which surface the flame spread rate is higher than 20mm/s.

When painting, use high quality tools and paints, follow the paint application manual and manufacturer's safety and usage instructions. Never paint a surface in strong sunlight or rainy weather.

After the house assembly is completed, we recommend for the conclusive finishing a weather protection paint that will protect wood from moisture and UV radiation.

- In lengthy periods of dry weather wood can shrink and the screw/bolt spots attachments can become weak. Conduct regular checks and tighten the screws/bolts as necessary (no less frequently than 6 month)! Otherwise the product may become dangerous.
- The suitability of the base material, corrosion of accessories and rotting of wooden parts should be checked once a year. Moving parts must be oiled and worn and/or defective parts should be replaced with parts provided by the manufacturer.
- Be especially attentive when checking barrier and door attachments.
- It is recommended to inspect the house thoroughly once in a year. Regular painting of the house will prolong its useful life substantially.
- You should also check the condition of the roof to discover any leaks as early as possible. Eliminate leaks as you find them to prevent rainwater from damaging the roof and other wooden parts of the house.

Attention! **For repairing the product use only identical details. The specification of the components can be found from the documentation accompanying the house package.**

2 Installation manual

Tools and preparation of components

To assemble the garden house, you will need the following tools:



assembly aid



ladder



hammer



water-level



screwdriver



saw



knife



measuring tape



pliers



set of drill



file



adjustable spanner



pencil

ADVICE: To avoid possible injuries from splinters, we recommend to wear the corresponding protective gloves during the assembly process. To protect your eyes from sawdust, we recommend to wear protective glasses during the assembly process.

Before screwing, please drill hole in order to avoid cracks in the wood.

All projecting screws and sharp edges must be panned smooth immediately after installation to avoid potential injuries.

Mark on the base surface the spots for the house pillars as indicated in this drawing:

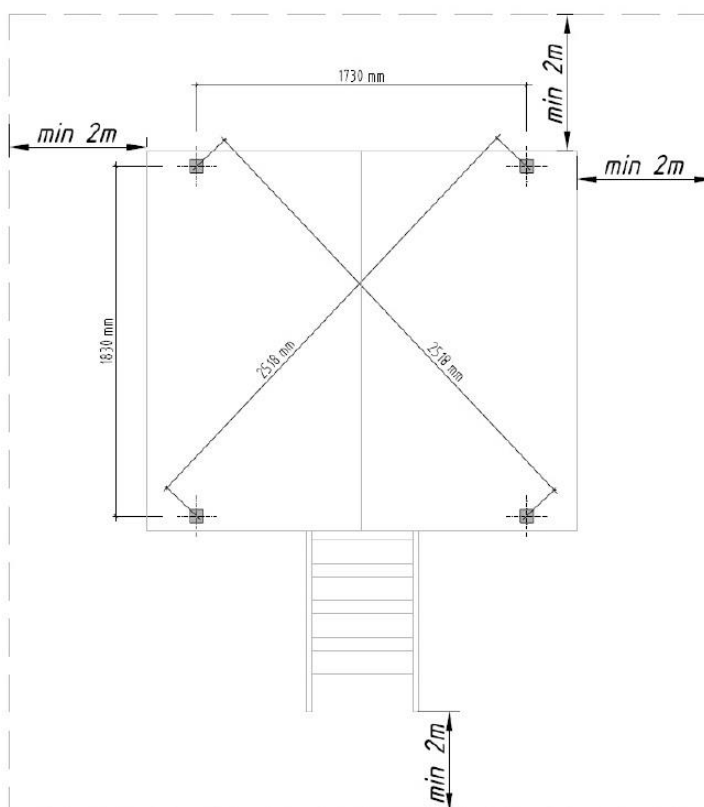

Installation manual - English

- **The house must be anchored to the base surface! It is not allowed to use a house that is not anchored! You must select the anchors (not included in the supplied kit) and the appropriate method of attachment depending on the base surface (see installation manual)!**
- **It is not allowed to use ground anchors (no concrete poured) with anchor bolts by attachment to pavement slabs!**

The house can be installed on either a soft (for instance: lawn) or hard (for instance: pavement slabs) surface.

A. Soft surface installation

When installing the house on a soft surface, use concrete forks (4 pcs), Art. 73530 (manufactured from structural steel S235 and reinforced steel DIN488,BST500).

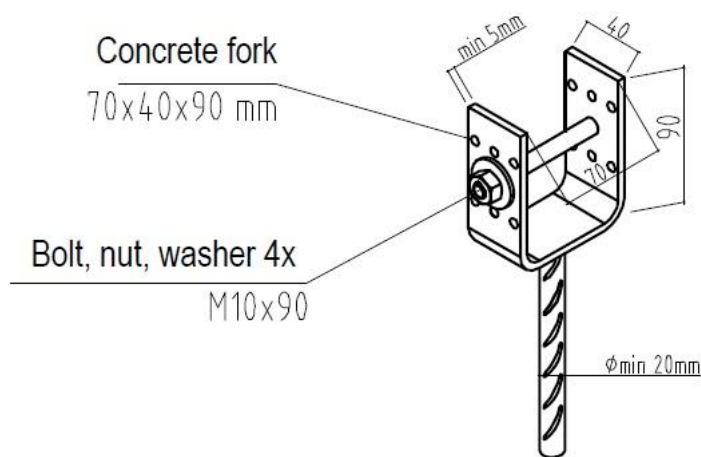

NB! The concrete forks are not included in the supplied kit!



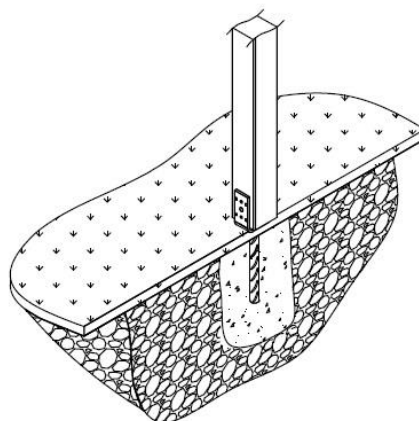

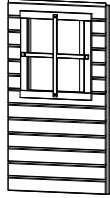
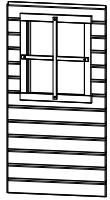
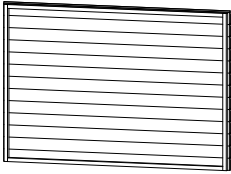
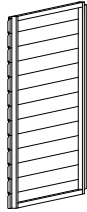
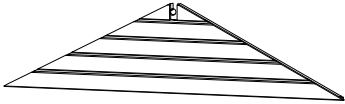
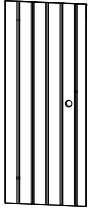
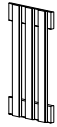
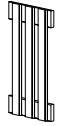
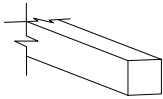
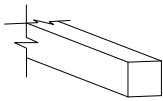

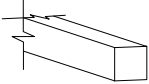
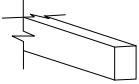
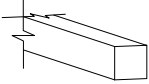
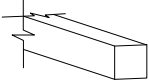
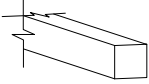
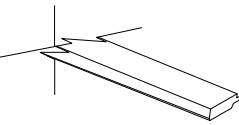
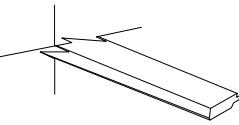
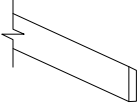
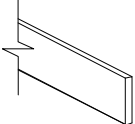
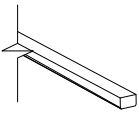
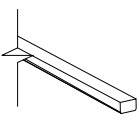
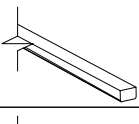
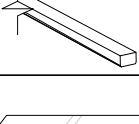

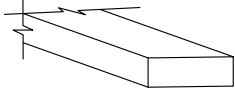
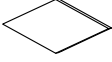
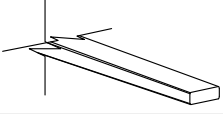
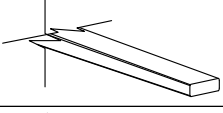
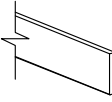
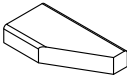
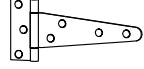

Dig a hole for each support (consult with a local construction company), fill it with concrete and place the concrete forks in the precisely measured spots. Make sure that all the concrete forks are situated at the same height! Allow sufficient time for the concrete to harden. After that put the house on the forks and attach with bolts.

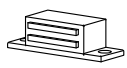

001.		1167x645x44	1
002.		1167x645x44	1
003.		1800x1167x44	1
004.		1190x1170x44	2
005.		1800x448x44	2
006.		1150x482x41	1
007.		610x610x32	2
008.		500x610x32	2
009.		70x70x1100	4
010.		70x70x1900	2

011.		70x70x1800	2
012.		70x45x1760	1
013.		70x70x430	8
014.		70x70x1480	2
015.		70x70x1200	2
016.		16x89x1800	22
017.		16x89x1190	44
018.		19x80x1900	4
019.		16x95x1220	4
020.		16x45x1220	4
021.		16x45x1900	2
022.		16x45x610	2
023.		16x45x500	2
024.		28x120x1467	1
025.		28x120x1467	1

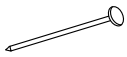
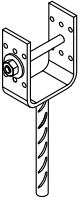
026.		28x120x530	4
027.		19x120x266	2
028.		12x24x500	2
029.		12x24x440	2
030.		19x70x576	1
031.		16x45x90	1
F1		80x150	2
F2		3x16	70
F3		46x15x13	1
F4		40x40x40	6
F5		40x40x20	20
F6		6x90	40
F7		3.5x40	120
F8		4.5x50	38
F9		3.5x30	46
F10		2.5x50	160
DE Nicht im Lieferumfang! EN Not included! ES No incluido! FR Non inclus! IT Non incluso!		NO Ikke inkludert! SW Ingår ej! FI Ei sisälly pakettiin! ET Ei sisaldu komplektis!	70x40x90 4

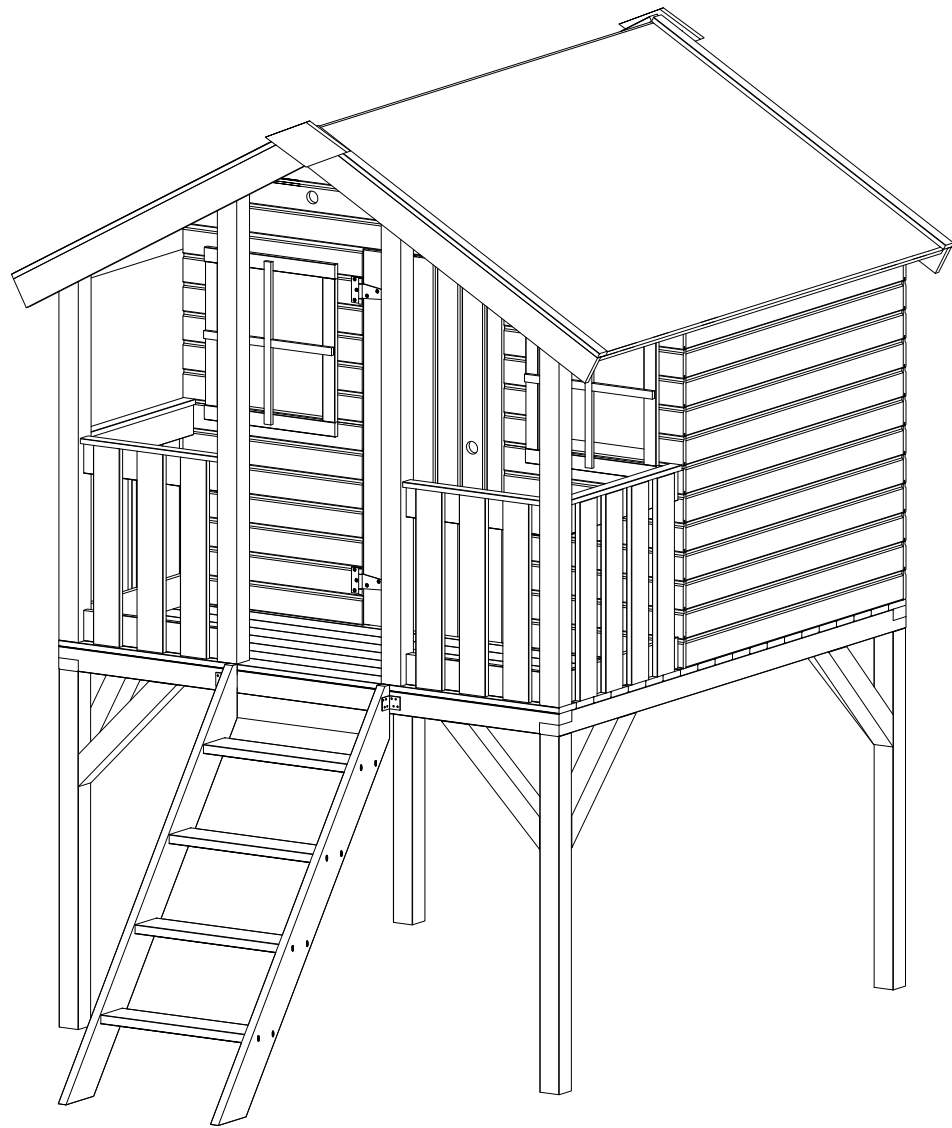

ELD16-1819



det 9 - 4 pcs
 det 10 - 2 pcs
 det 11 - 2 pcs
 F6 - 8 pcs

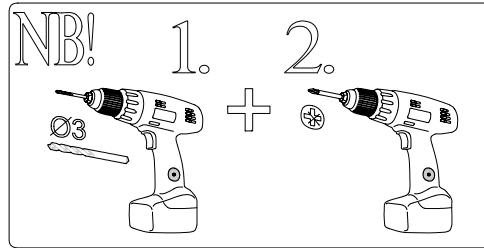

1

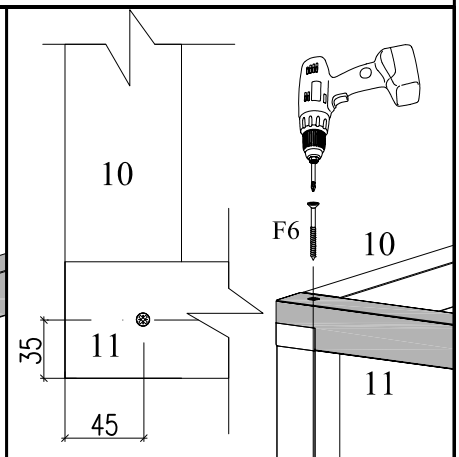
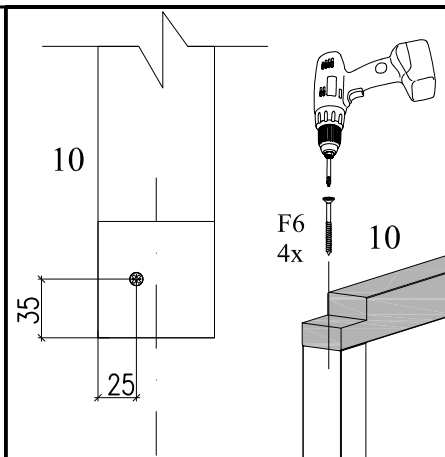
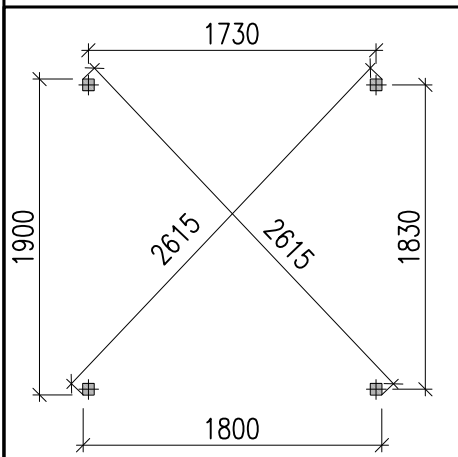
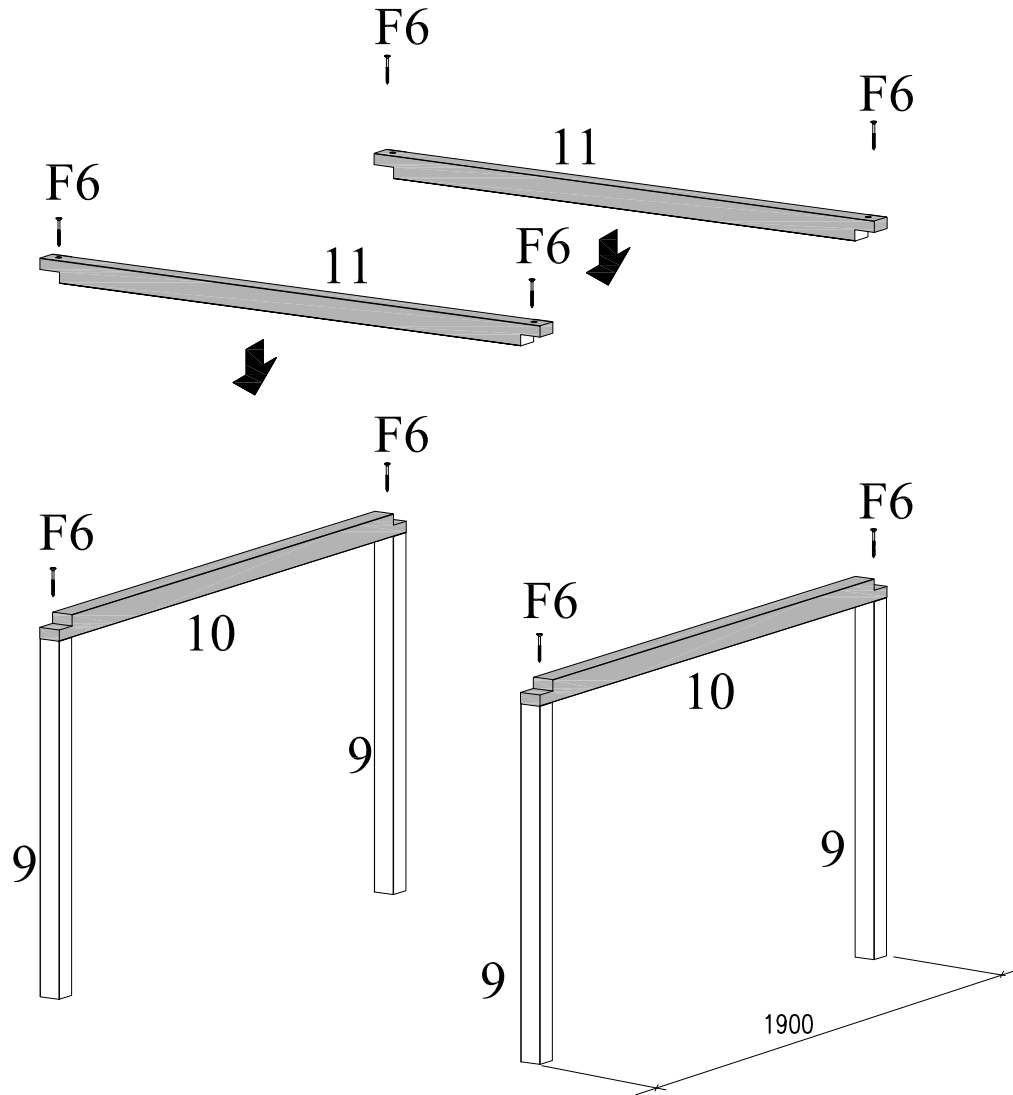

det 12 - 1pcs
det 13 - 8 pcs
F4 - 4 pcs
F6 - 16 pcs
F7 - 32 pcs

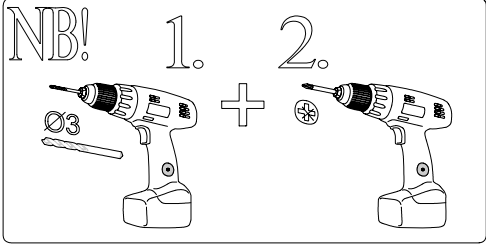

2

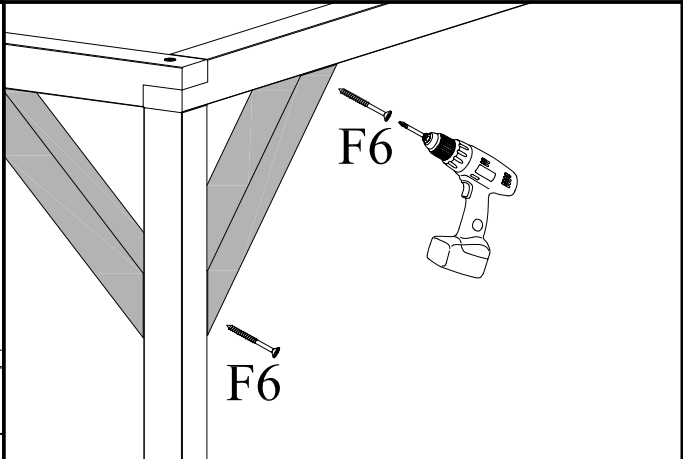
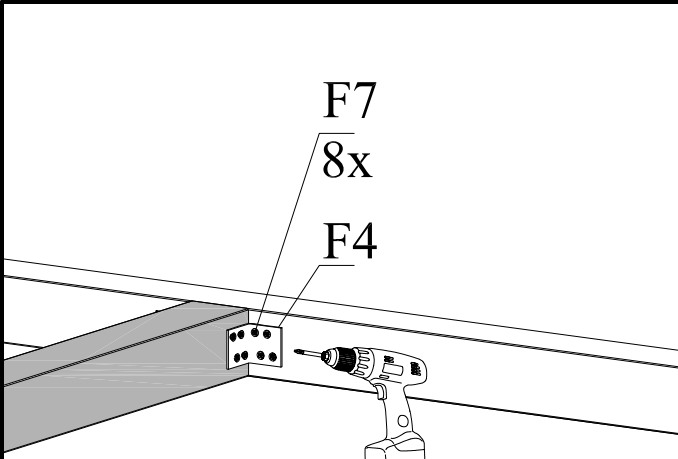
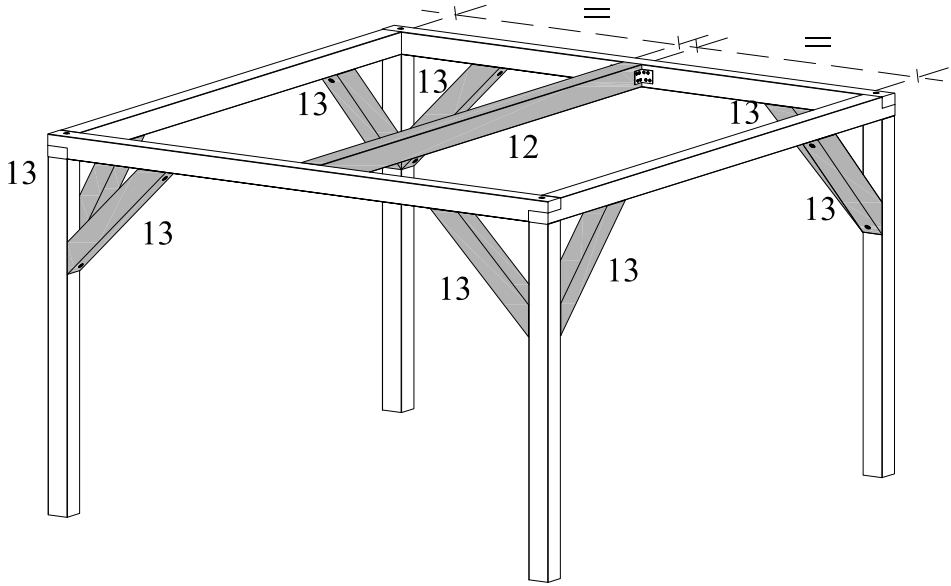

det 16 - 22 pcs
F10 - 66 pcs

3

16 (22x)

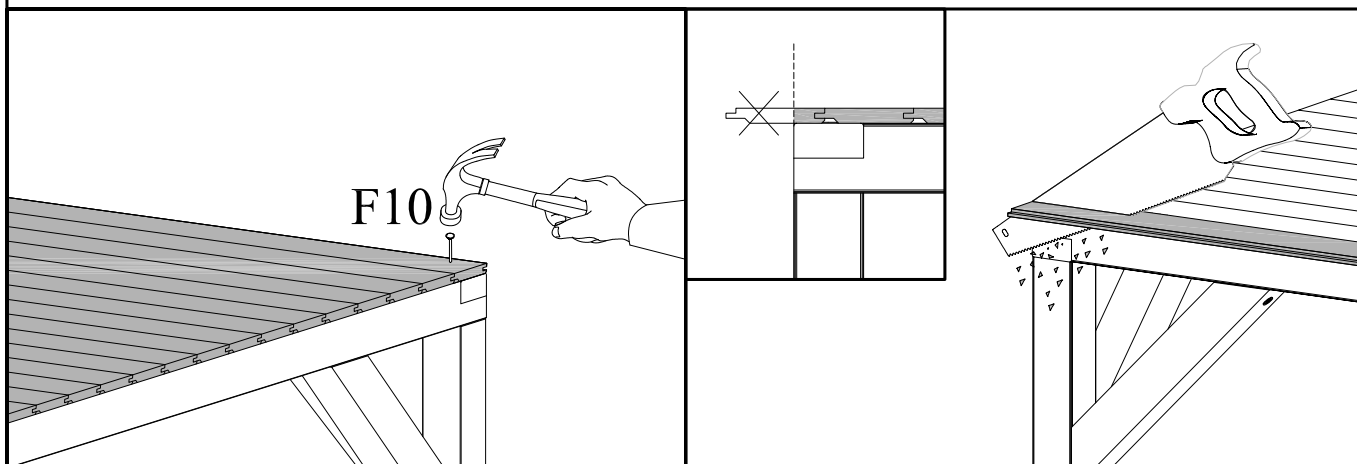
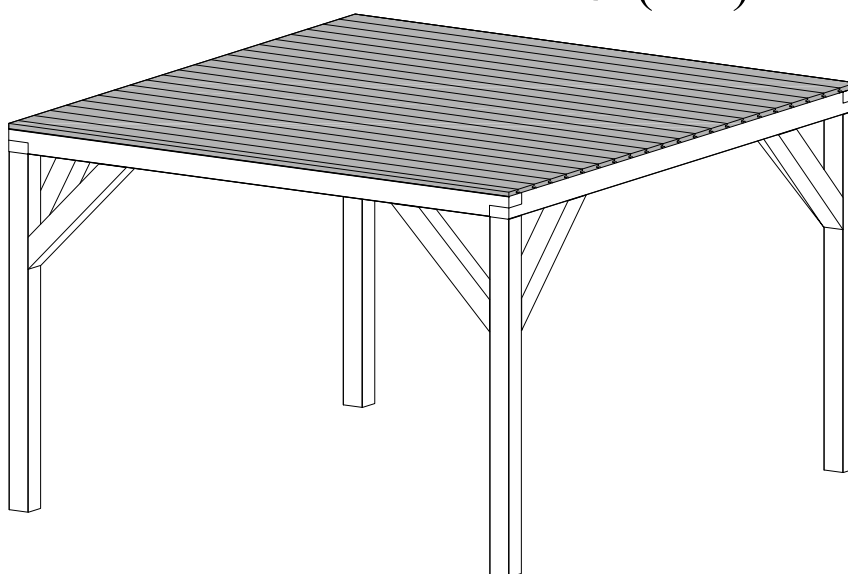

det 3 - 1 pcs

F8 - 4 pcs

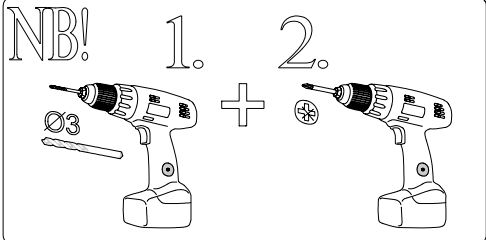

4

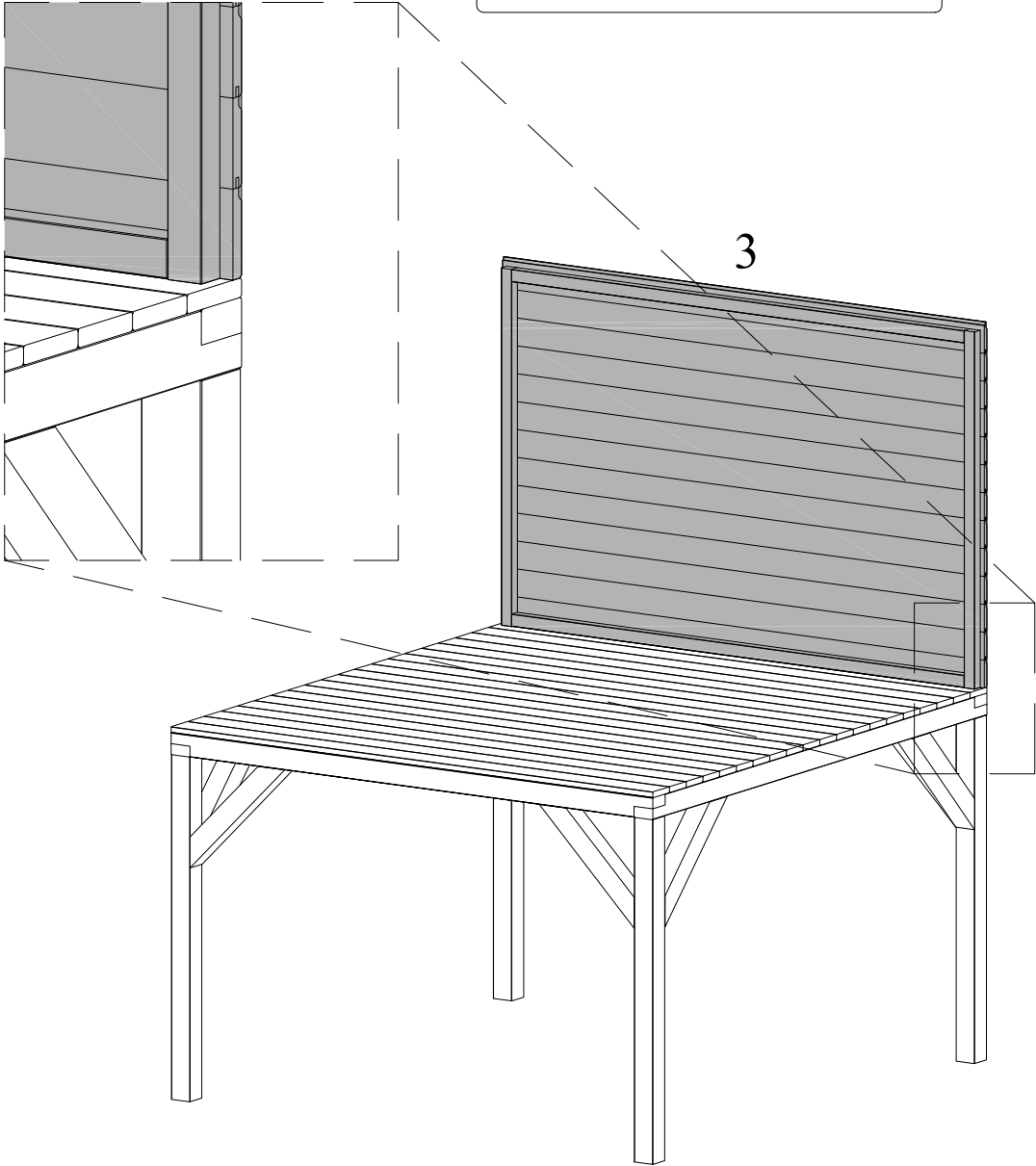

F8
4x

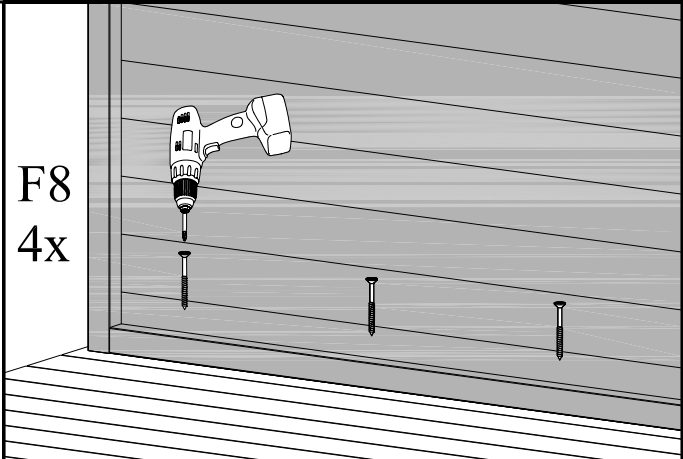

det 4 - 2 pcs

F8 - 12 pcs

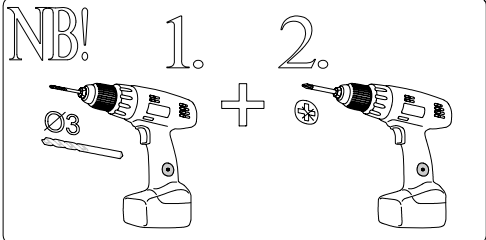

5

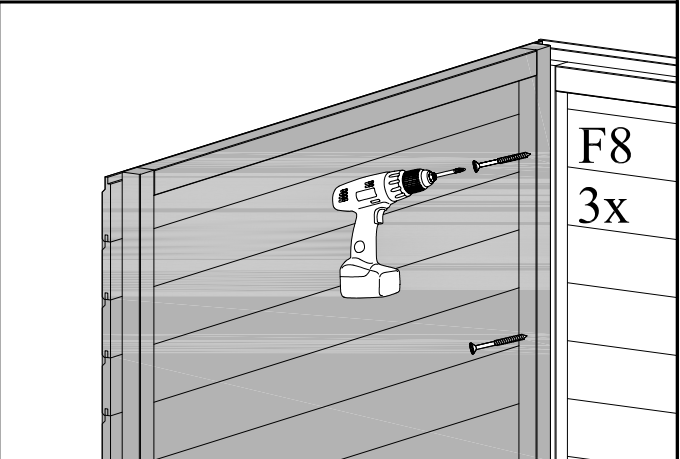
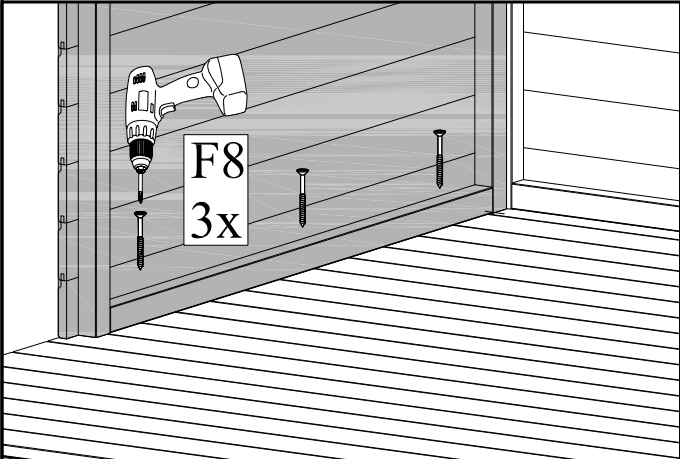
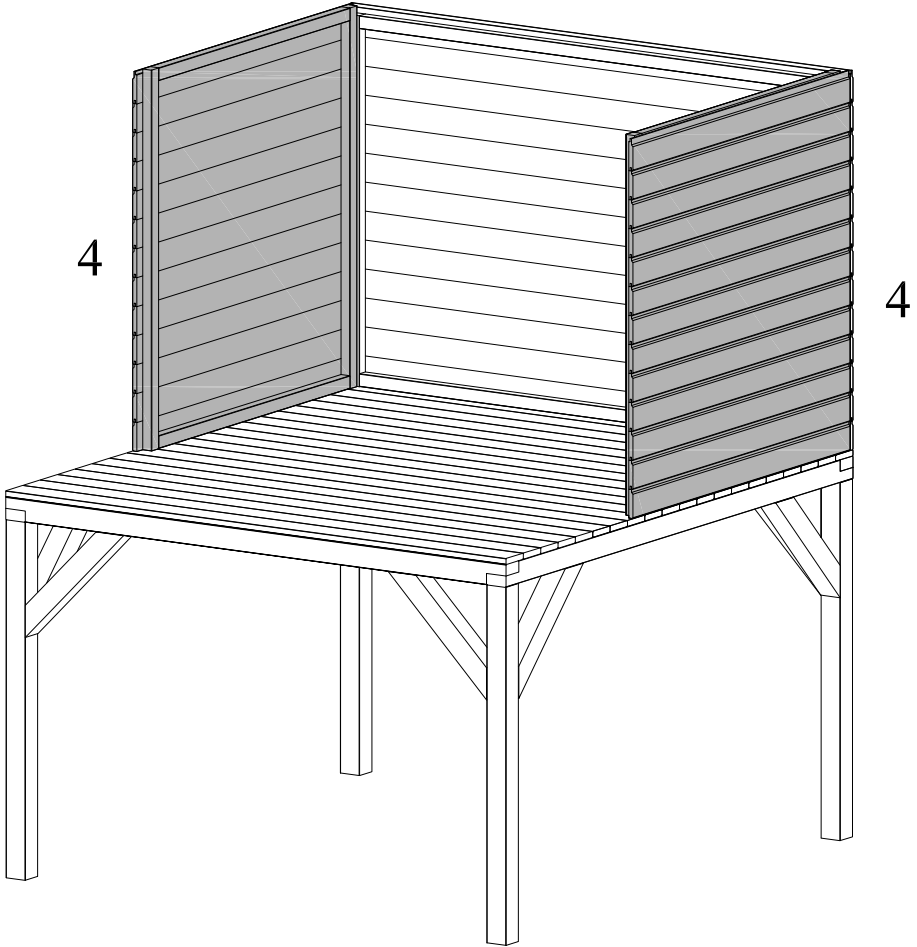

- det 1 - 1 pcs
- det 2 - 1 pcs
- det 28 - 2 pcs
- det 29 - 2 pcs
- F9 - 8 pcs
- F8 - 6 pcs
- F7 - 8pcs

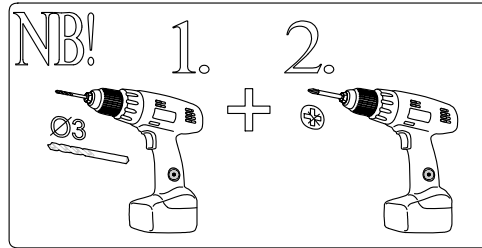

6

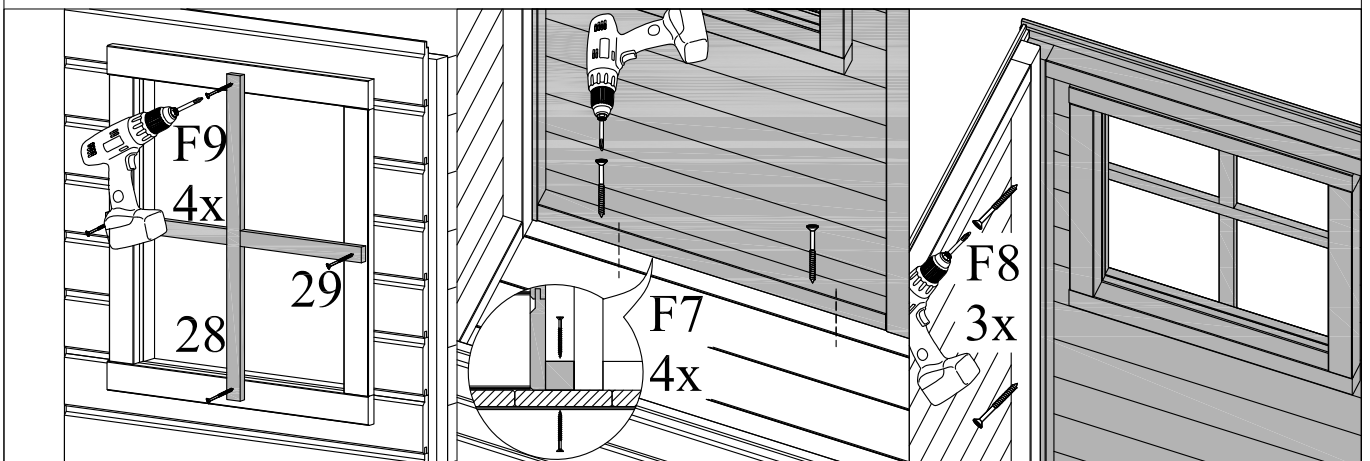
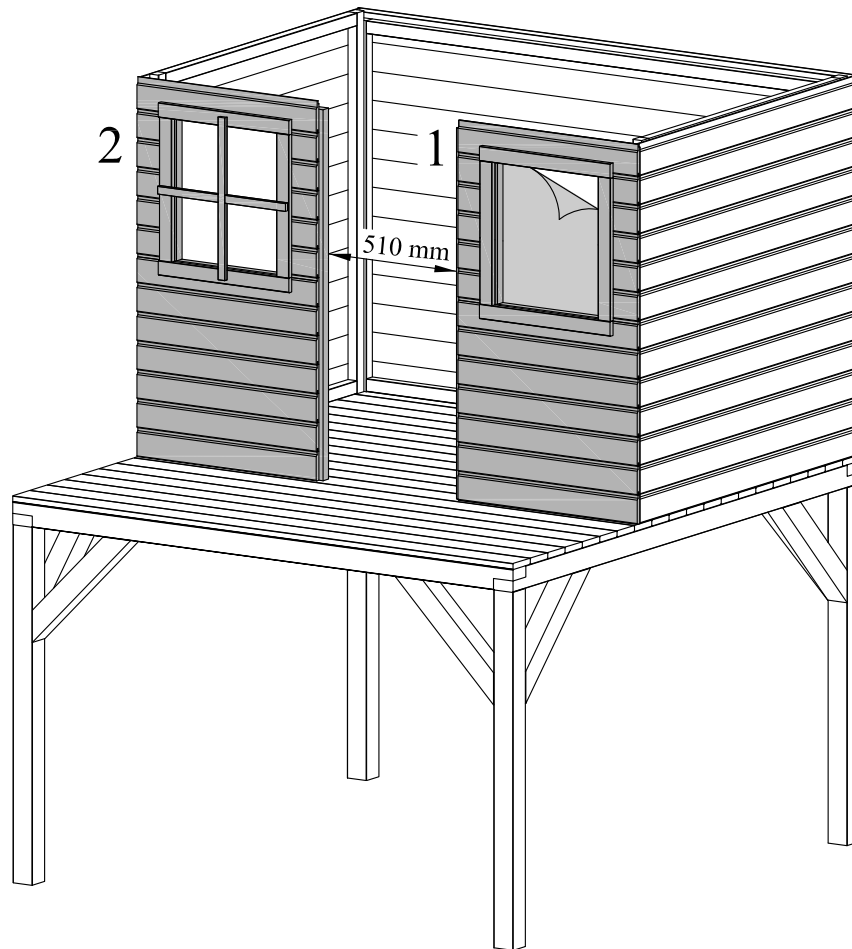

det 5 - 2 pcs

F8 - 8 pcs

F3 - 1 pcs

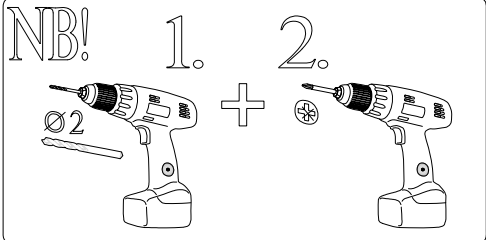

7

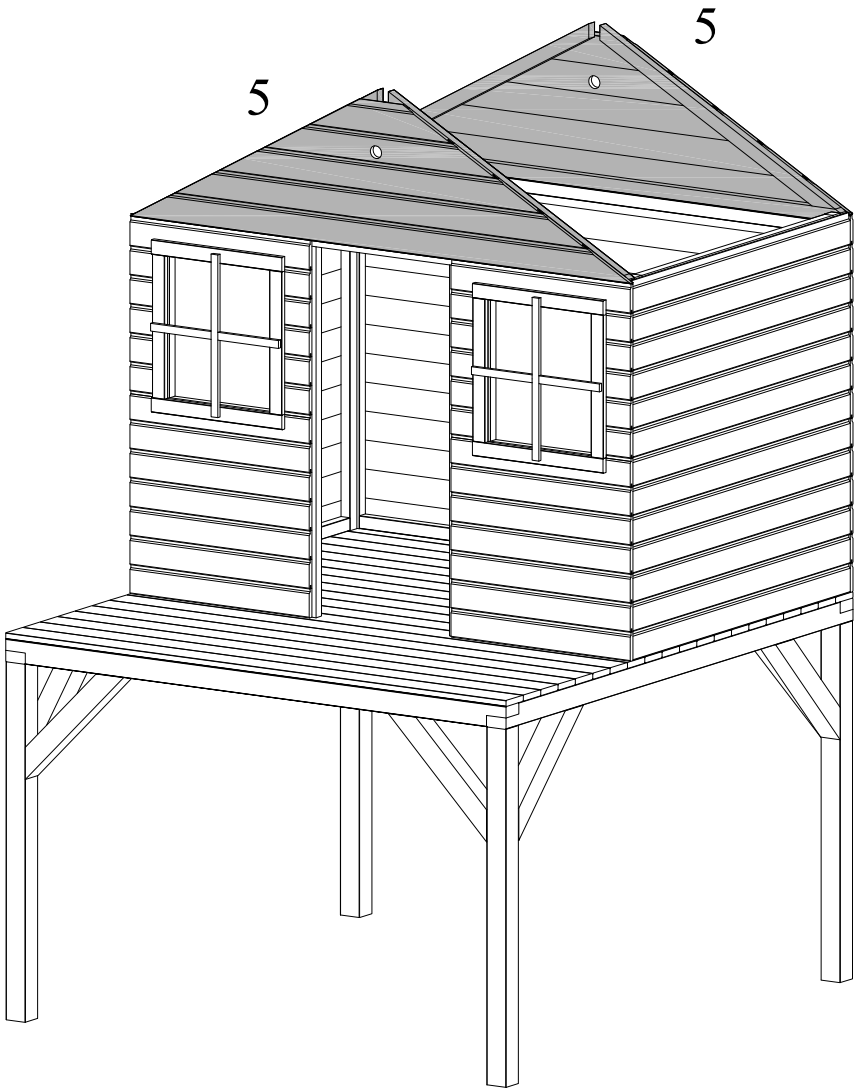

- det 6 - 1 pcs
- det 31- 1 pcs
- F1 - 2 pcs
- F2 - 2 pcs
- F3 - 1 pcs
- F7 - 12 pcs
- F9 - 2 pcs

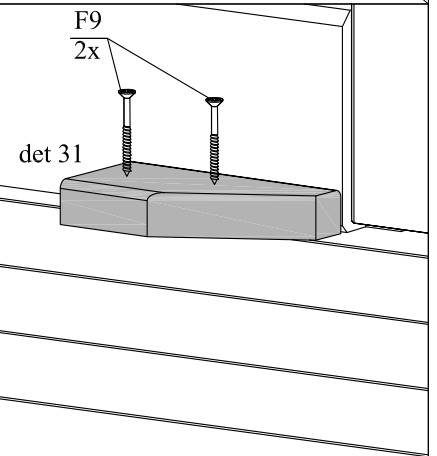
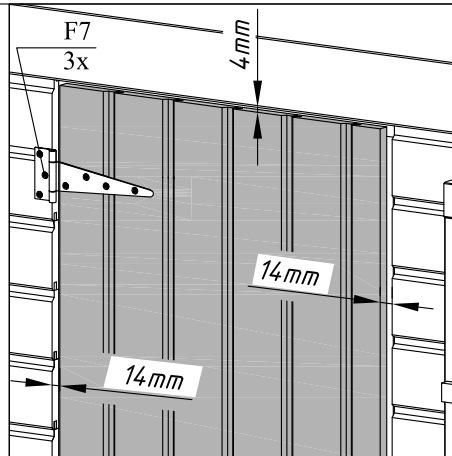
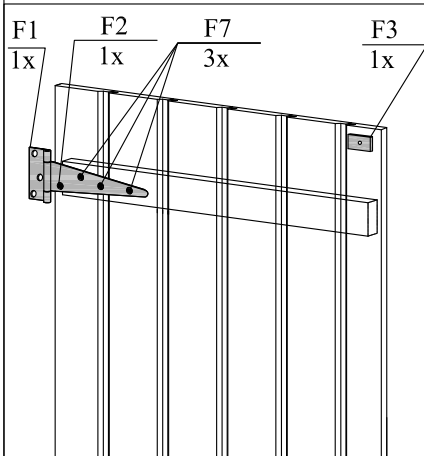
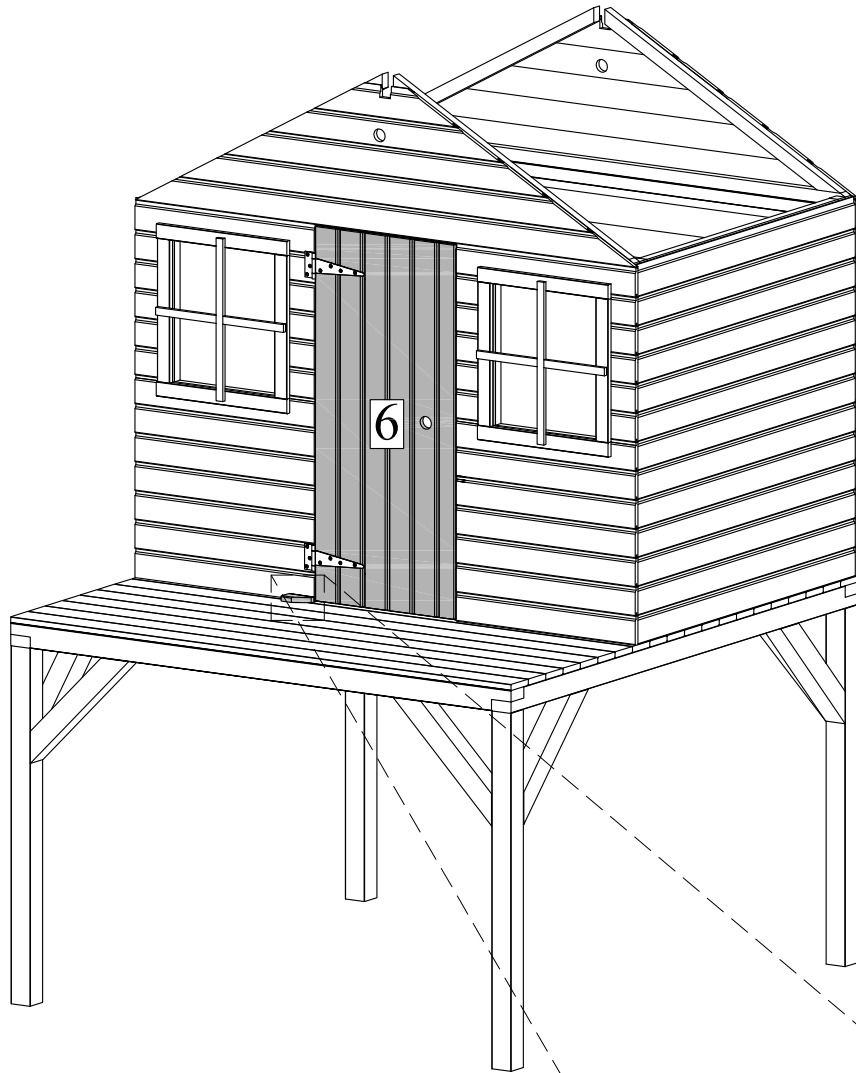
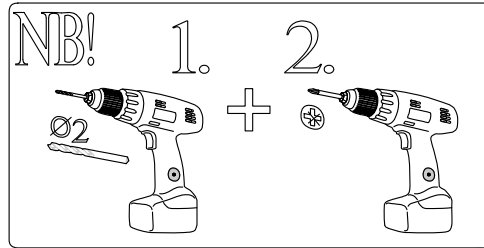

det 18 - 4 pcs
F7 - 10 pcs
F9 - 8 pcs

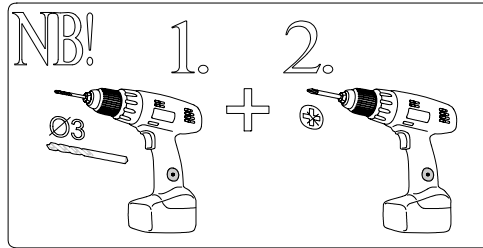

9

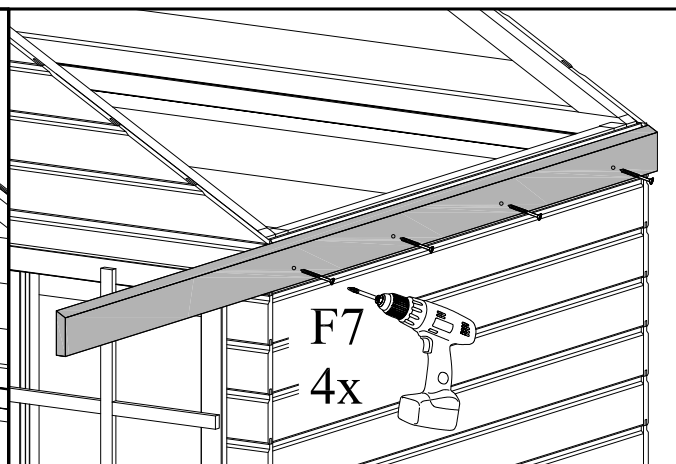
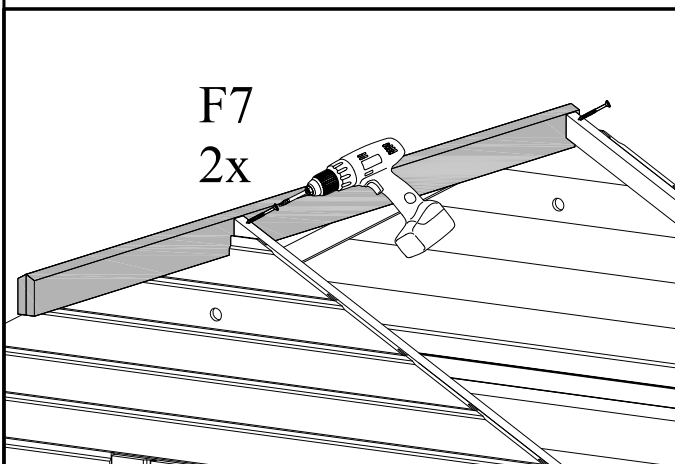
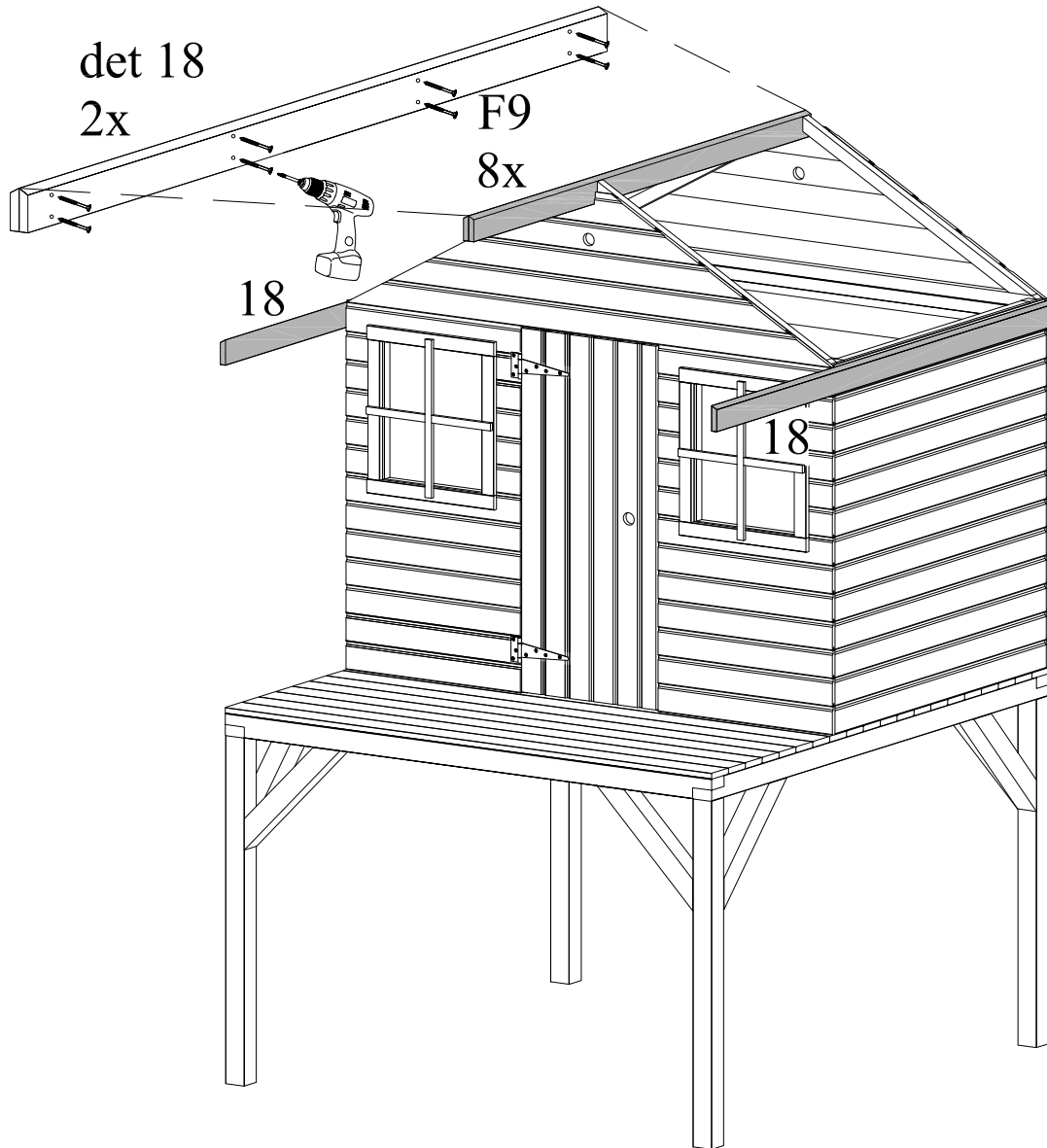

det 15 - 2 pcs
det 17 - 44 pcs
F5 - 2 pcs
F7 - 10 pcs
F10 - 88 pcs

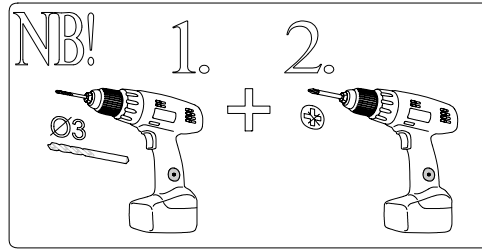

10

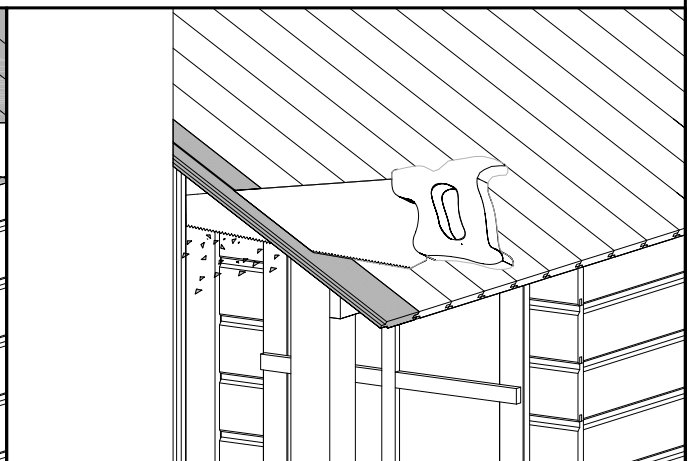
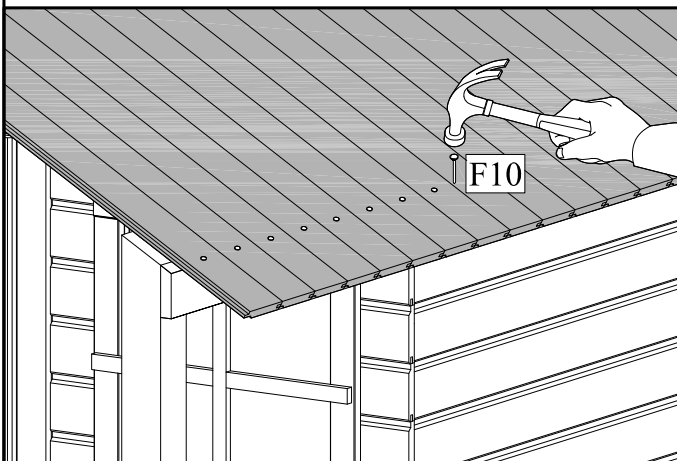
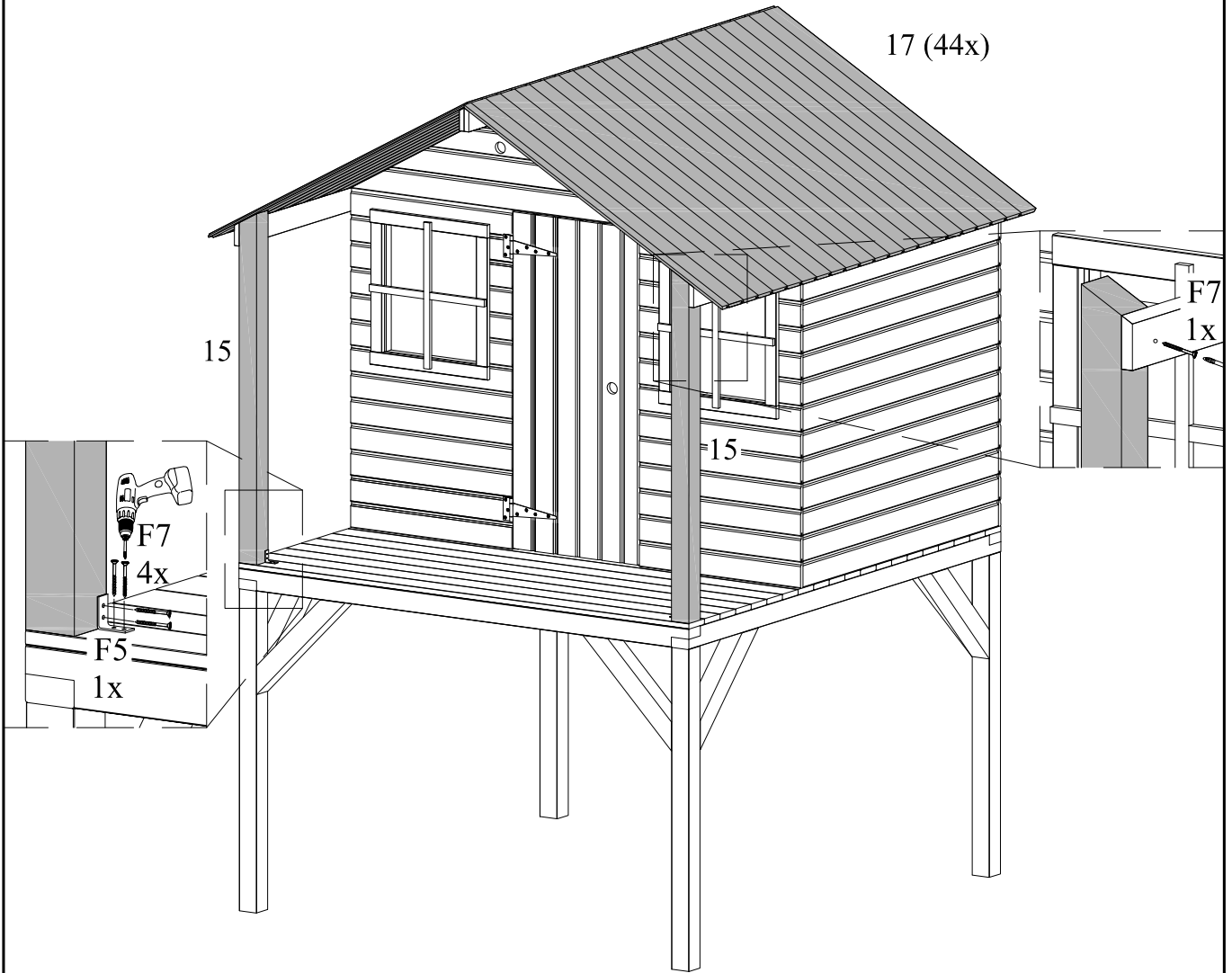

det 14 - 2 pcs

F5 - 2 pcs

F7 - 8 pcs

F8 - 2 pcs

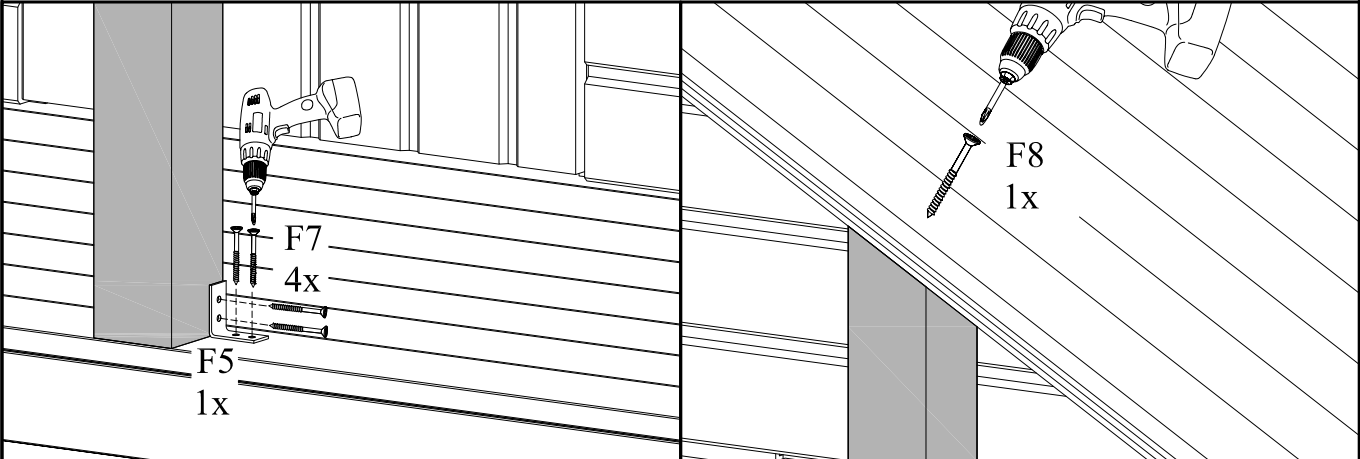
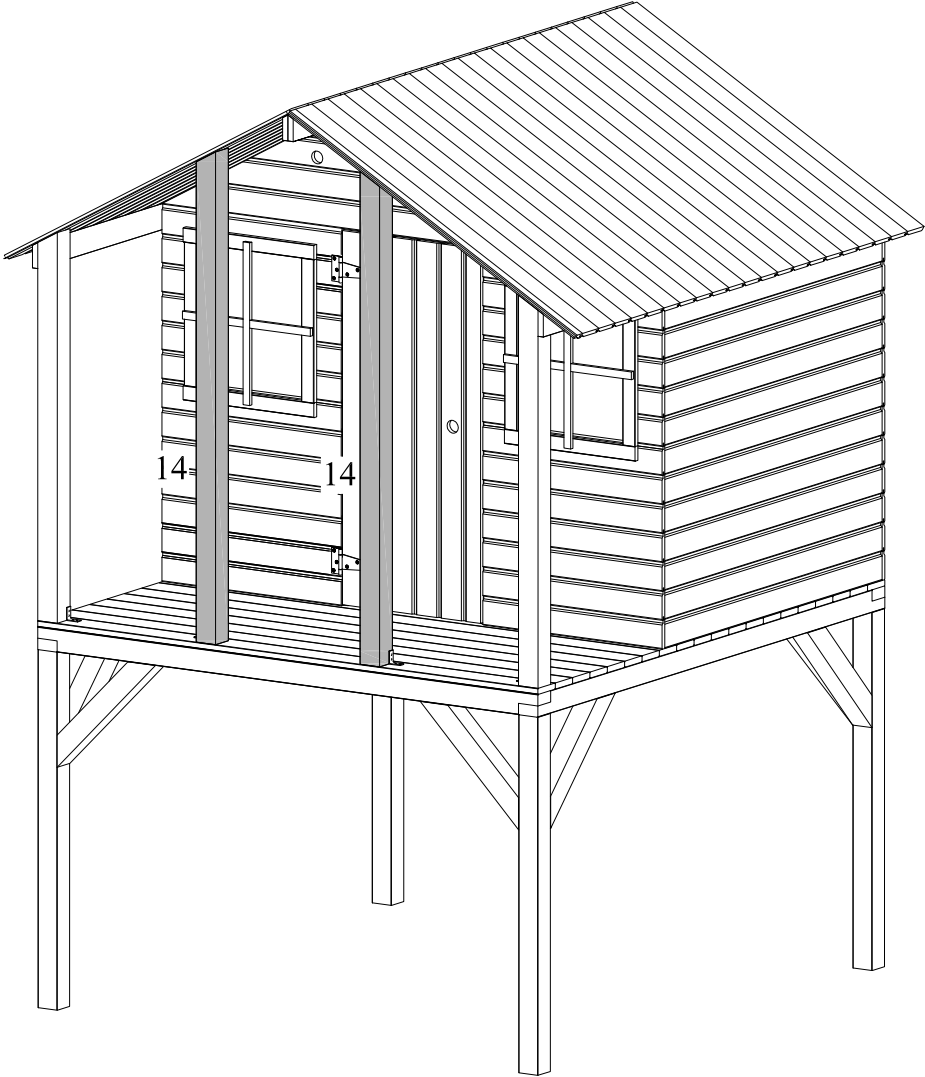
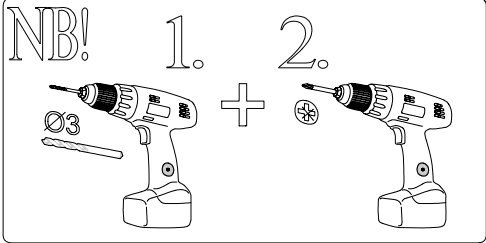

- det 7 - 2 pcs
- det 8 - 2 pcs
- det 22 - 2 pcs
- det 23 - 2 pcs
- F5 - 16 pcs
- F2 - 64 pcs
- F7 - 8 pcs

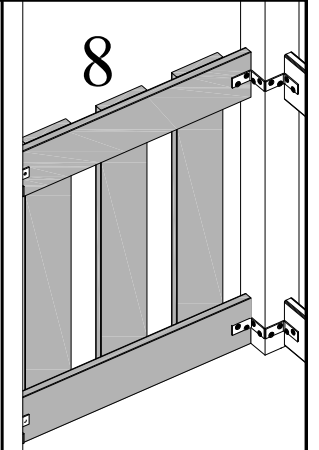
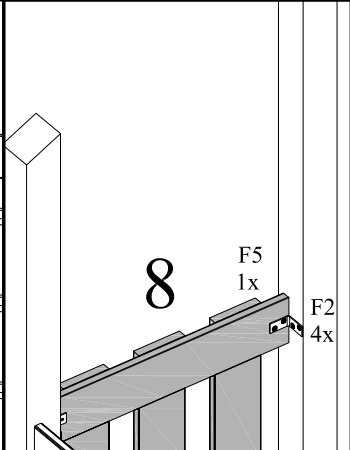
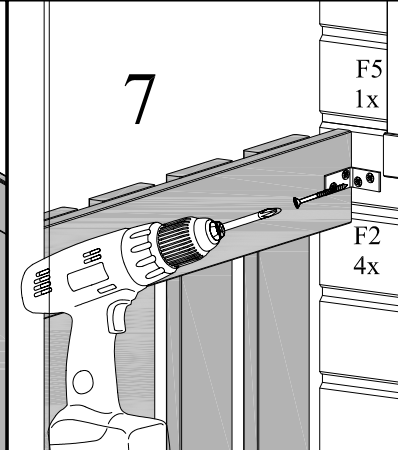
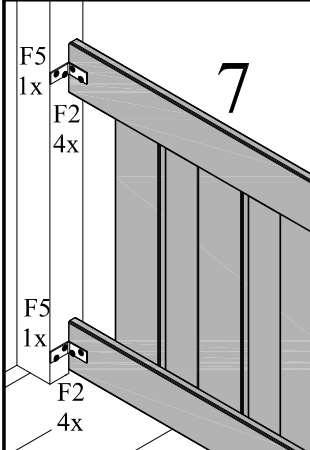
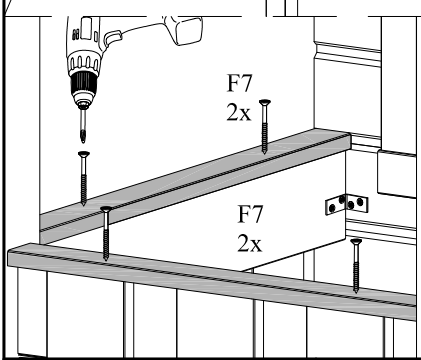
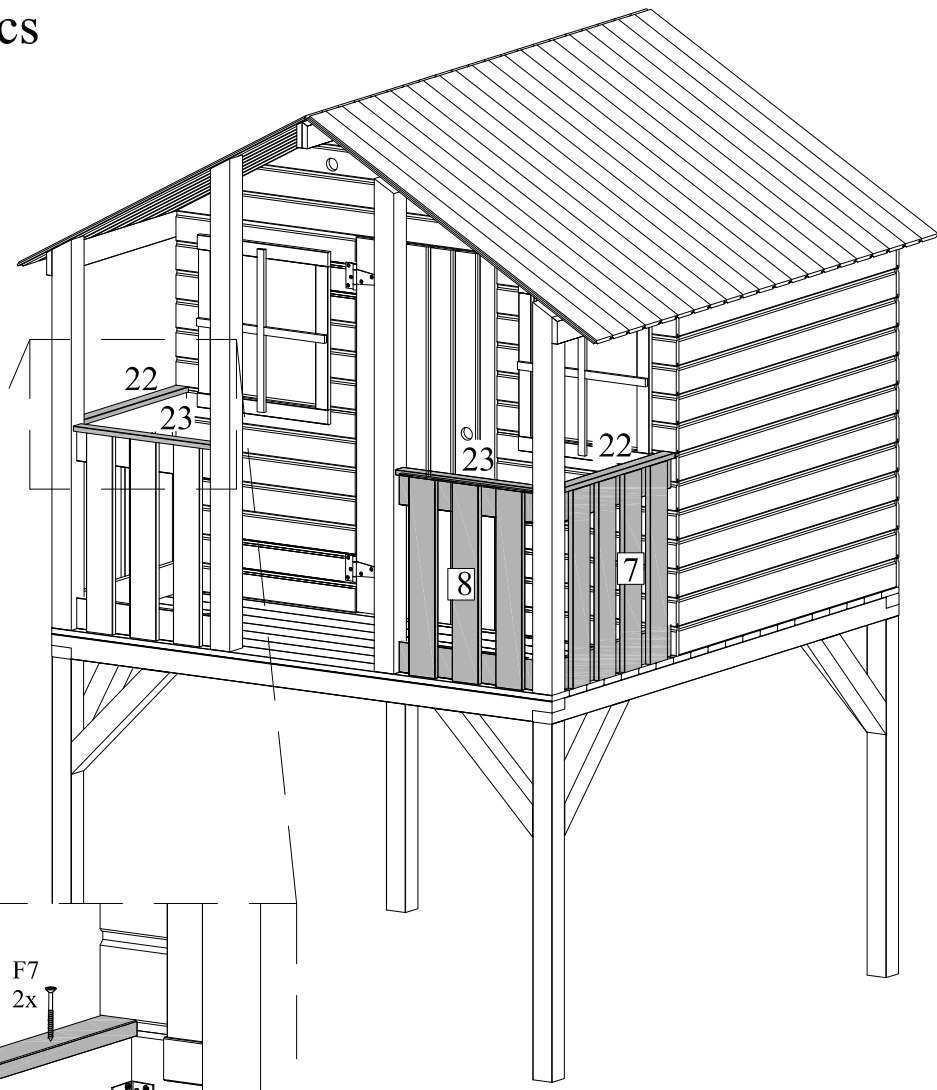
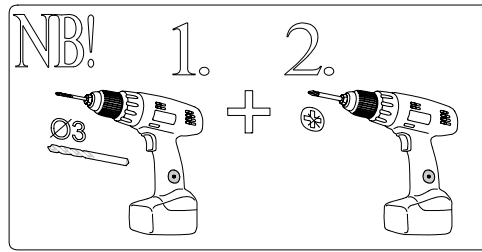

EN - Not included in the kit: roof cover material.

DE - Nicht im Lieferumfang: Dacheindeckung.

ES - No incluidos en el kit: material de cubierta de techo.

NL - Niet inbegrepen in de kit: dakbedekkingsmateriaal.

IT - Non inclusi nel kit: materiale di copertura del tetto.

PT - Não incluídos no kit: material para a cobertura de teto.

FR - Non inclus dans le kit : matériau de couverture de toit.

DK - Ikke inkluderet i sættet: tagdækningsmateriale.

LV - Komplektā neietilpst: jumta seguma materiāls.

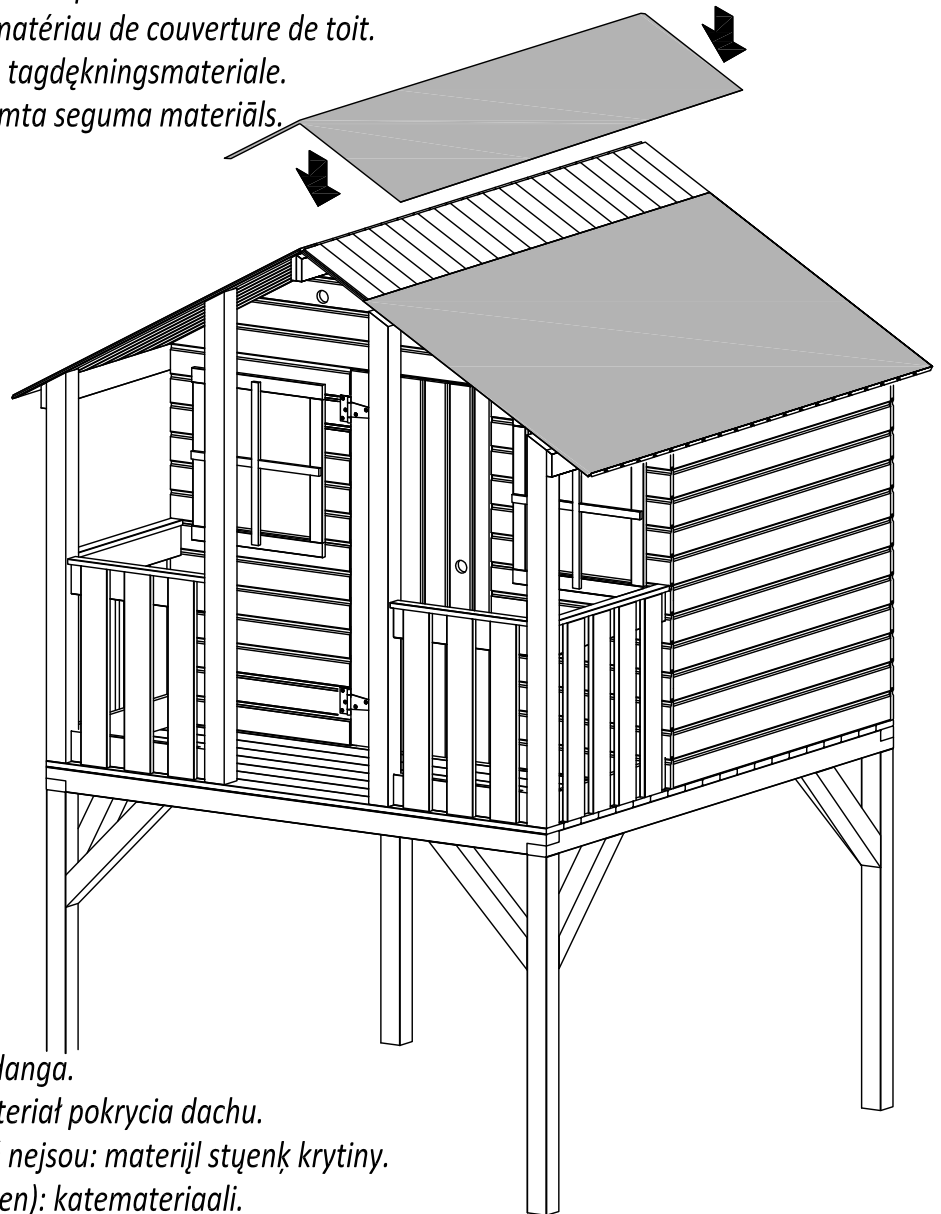

LT - Komplekte nėra: stogo dangą.

PL - Zestaw nie zawiera: materiał pokrycia dachu.

CZ - Důležité! Součástí hříště nejsou: materiál stýenky krytiny.

FI - Lisäosat (tilattava erikseen): katemateriaali.

SE - Följande ingår ej: takbeläggningmaterial.

NO - Inngår ikke i settet: taktekke.

ET - Katusekattematerjal ei sisaldu komplektis.

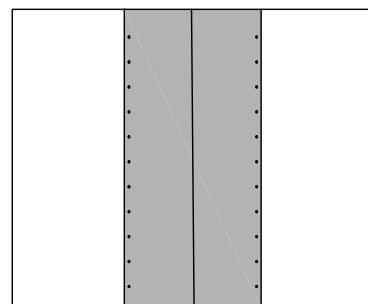
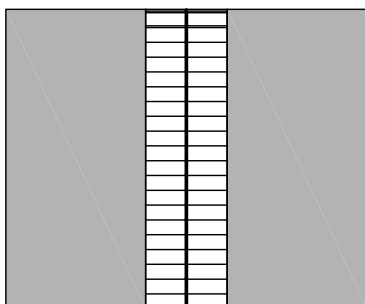

det 19 - 4 pcs
det 21 - 2 pcs
F7 - 16 pcs
F9 - 8 pcs

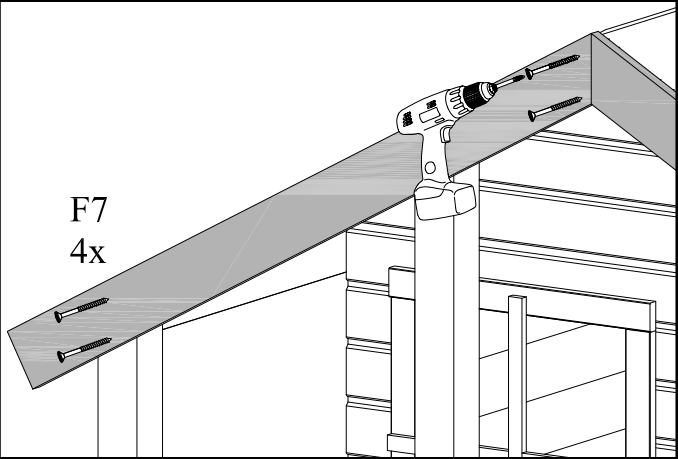
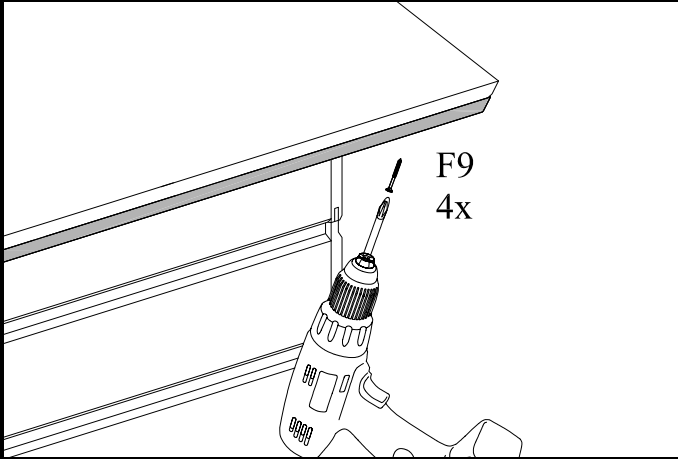
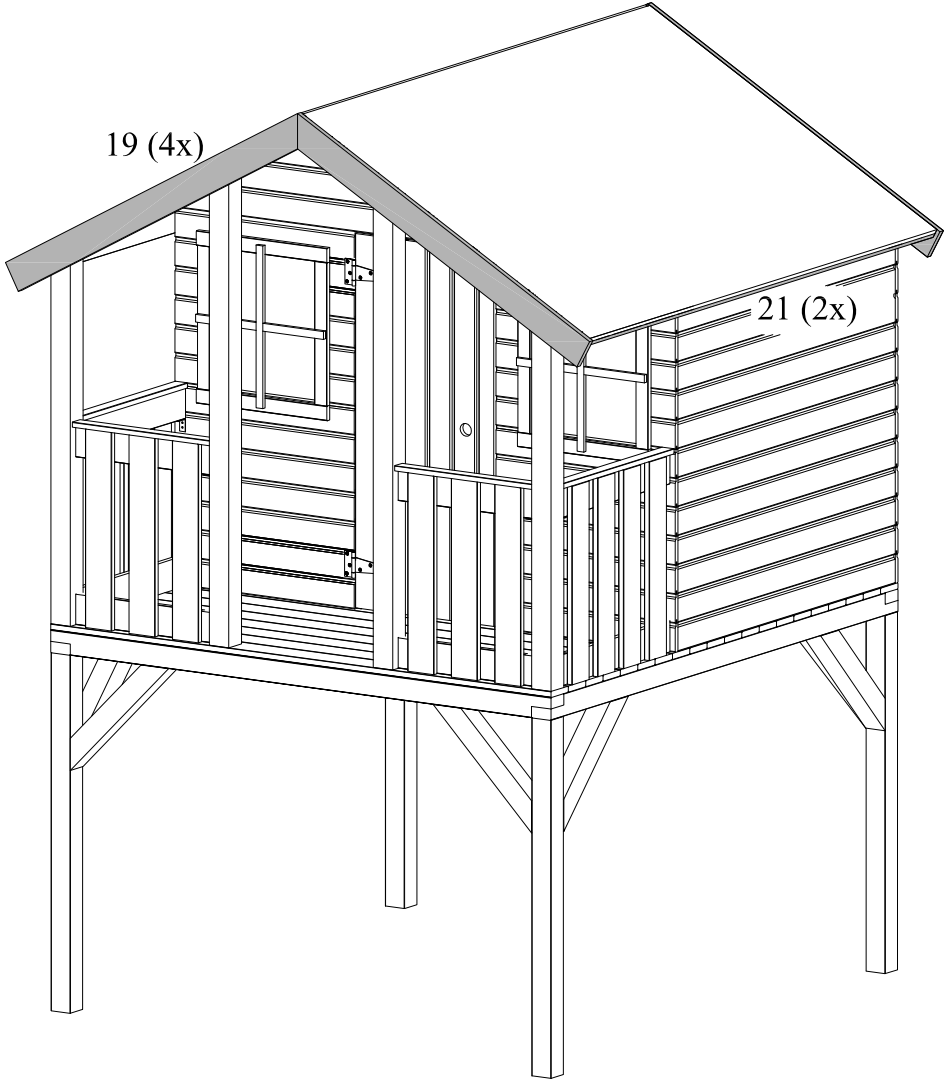
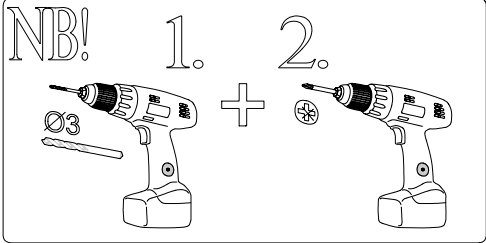

det 20 - 4 pcs
det 27 - 2 pcs
F7 - 16 pcs

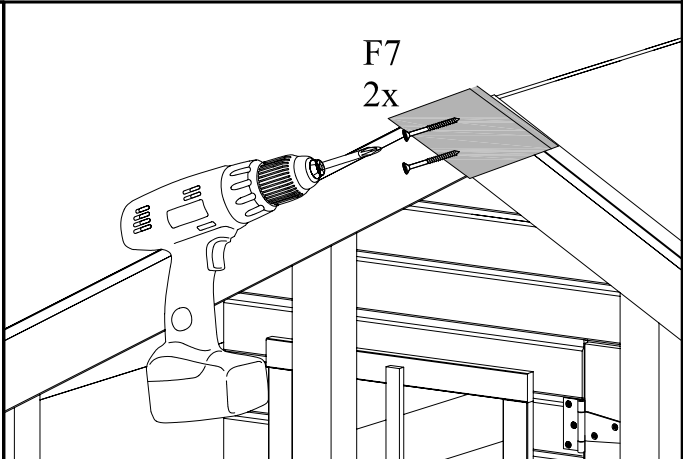
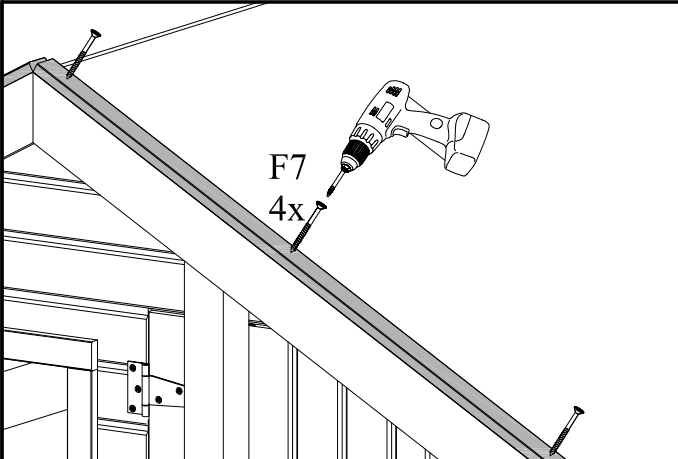
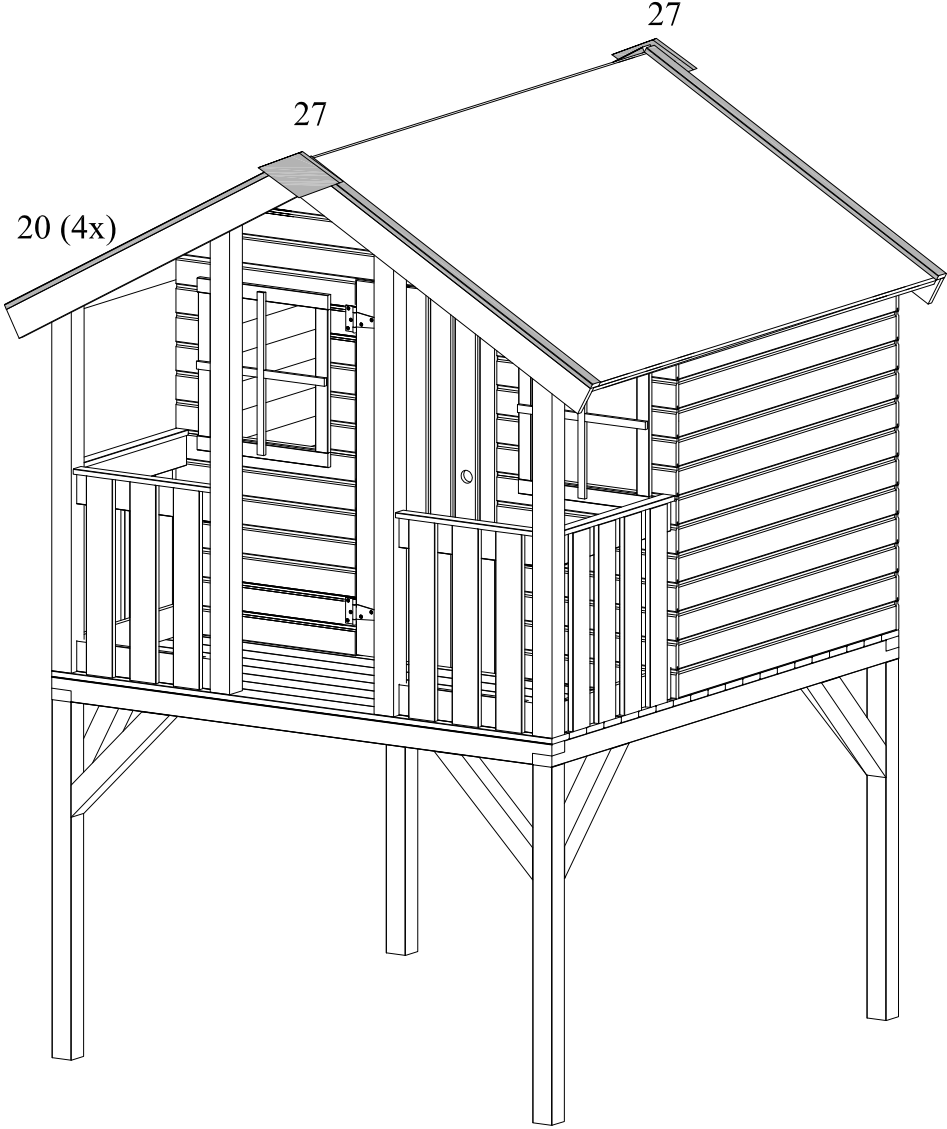
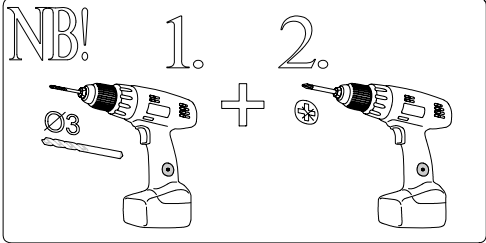

- det 24 - 1 pcs
- det 25 - 1 pcs
- det 26 - 4 pcs
- det 30 - 1 pcs
- F6 - 16 pcs
- F4 - 2 pcs
- F9 - 16 pcs
- F8 - 2 pcs

