



# Assembly, installation and maintenance manual

## FRANKLIN Playhouse

Width 199 x Depth 163 cm  
Wall thickness 16 mm



### **WARNINGS:**

Not suitable for children under 3 years. Risk of crushing.

To be used under the direct supervision of an adult. Risk of falling.

Only for outdoor domestic use.

Keep away from fire.

The product is supplied disassembled. Adult assembly required.

Intended for children from 3 to 14 years (max 50 kg/user).

### **Attention!**

- It is not allowed to climb on the barriers and roof of the assembled house.
- Caution. Wooden details can contain slight torn grain or sharp ends and edges.
- The product is designed for simultaneous use by up to 6 persons.
- The supplied kit does not include any roof cover material. Before you begin using the house, you must obtain a suitable roof cover material (bitumen shingles or rolls) and install it in accordance with the manufacturer's instructions! It is not recommended to leave the house without a roof cover in the rain or it will void the warranty!
- The product is delivered unfinished.

## 1 Assembly manual



**Dear client,**

We are glad that you have decided in favour of our garden house!

**Please read the assembly manual carefully before proceeding with the house installation!** You will thus avoid problems and will not waste time.

### **Recommendations:**

- Keep the house package until its complete assembly in a dry place, but not in direct contact with the ground, protected from weather conditions (moisture, the sun, etc.). Do not keep the house package in a heated room!
- Assemble the product on the smooth surface at least 2m from any construction or barrier such as fence, garage, house, above situated tree branches, clotheslines and electric cables.
- When selecting the garden house location, make sure that the house will not be subjected to extreme weather conditions (areas of strong snowfall or winds); otherwise you should attach the house (for instance, with anchors) to the subsoil.
- Since the foundation joists are in constant contact with the ground they must be treated with a special wood preservative. Consult a specialist regarding paints suitable for unprocessed softwood and follow the paint manufacturer's instructions.



### **Warranty**

Your house is made from high quality fir and delivered in the natural (unprocessed) form. If, despite our thorough inspection, you should have complaints, please submit the filled out control sheet and purchase invoice to the product seller.

**ATTENTION: Please be sure to keep the documentation accompanying the house package! The control sheet includes the control number of the house. We can only review complaints if you submit the control number of the house to the seller!**

#### The warranty does not cover:

- Peculiarities of wood as a natural material
- Wooden details already painted (processed with a wood preservative)
- Wooden details containing whole branches that do not endanger the stability of the house
- Colour tone variations caused by wood structure differences that do not influence wood lifetime
- Wooden details containing (caused by drying) small cracks/gaps that do not pass through and do not influence the structure of the house
- Twisted wooden details if they can nevertheless be installed
- Roof and floor boards that may have on their concealed surfaces some non-planed areas, colour differences and waning
- Complaints resulting from an incompetent manner of the installation of the house or the house subsiding due to an incompetently made foundation
- Complaints caused by introducing self-initiative changes to the house, such as the deformation of wooden details and doors/windows due to an incompetent manner of wood processing; the attachment of storm braces too rigidly, doorframes being screwed onto wall logs, etc.

**The complaints covered by the warranty are satisfied to the extent of replacing the deficient/faulty material. All other demands will be excluded!**



### Garden house painting and maintenance

Wood is a natural material, growing and adapting depending on weather conditions. Large and small cracks, colour tone differences and changes, as well as a changing structure of wood are not errors, but a result of wood growing and a peculiarity of wood as a natural material.

Unprocessed wood becomes greyish after having been left untouched for a while, and can be turn blue and become mouldy. To protect the wooden details of your garden house, you must immediately process them with a wood preservative.

**Attention!**      **The house is supplied without elaborative workmanship. To reduce fire hazard you should use paints or impregnation substances that prevent fire from spreading! Use water-based paints and impregnation substances and avoid solvent-based products!**

**Consult a specialist regarding paints suitable for unprocessed softwood and follow the paint manufacturer's instructions.**

**It is not allowed to cover the product with lacquer or paint on which surface the flame spread rate is higher than 20mm/s.**

When painting, use high quality tools and paints, follow the paint application manual and manufacturer's safety and usage instructions. Never paint a surface in strong sunlight or rainy weather.

After the house assembly is completed, we recommend for the conclusive finishing a weather protection paint that will protect wood from moisture and UV radiation.

- In lengthy periods of dry weather wood can shrink and the screw/bolt spots attachments can become weak. Conduct regular checks and tighten the screws/bolts as necessary (no less frequently than 6 month)! Otherwise the product may become dangerous.
- The suitability of the base material, corrosion of accessories and rotting of wooden parts should be checked once a year. Moving parts must be oiled and worn and/or defective parts should be replaced with parts provided by the manufacturer.
- Be especially attentive when checking barrier and door attachments.
- It is recommended to inspect the house thoroughly once in a year. Regular painting of the house will prolong its useful life substantially.
- You should also check the condition of the roof to discover any leaks as early as possible. Eliminate leaks as you find them to prevent rainwater from damaging the roof and other wooden parts of the house.

**Attention!**      **For repairing the product use only identical details. The specification of the components can be found from the documentation accompanying the house package.**



**We wish you total success with the garden house installation and much joy with this house for many years to come!**

## 2 Installation manual

### Tools and preparation of components

To assemble the garden house, you will need the following tools:



assembly aid



ladder



hammer



water-level



screwdriver



saw



knife



measuring tape



pliers



set of drill



file



adjustable spanner



pencil









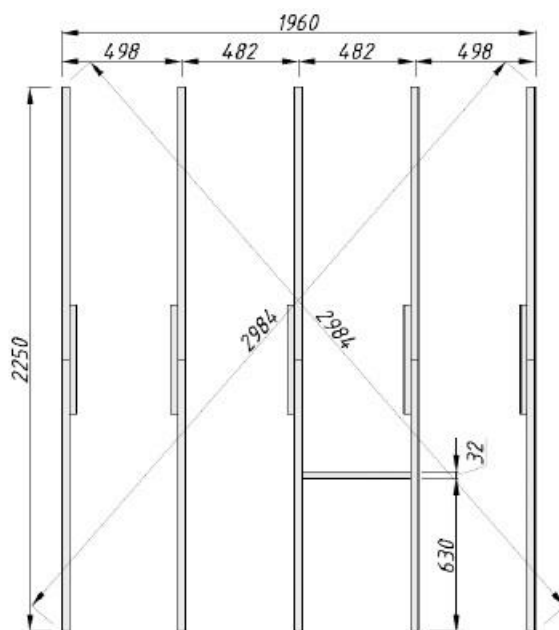

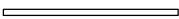

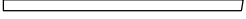

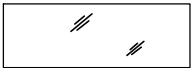

**ADVICE:** To avoid possible injuries from splinters, we recommend to wear the corresponding protective gloves during the assembly process. To protect your eyes from sawdust, we recommend to wear protective glasses during the assembly process.





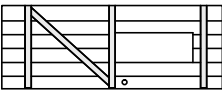
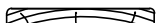

Before screwing, please drill hole in order to avoid cracks in the wood.

All projecting screws and sharp edges must be panned smooth immediately after installation to avoid potential injuries.

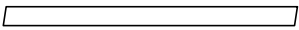
Level the ground and install the foundation joists according to the drawing below:

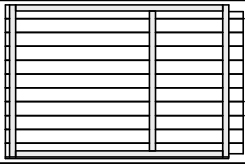
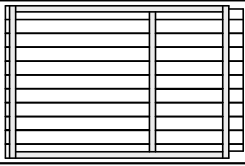
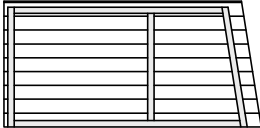
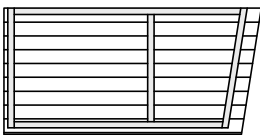
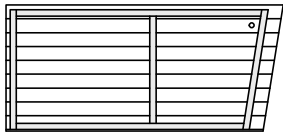
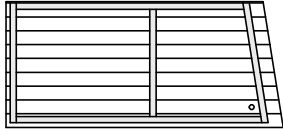
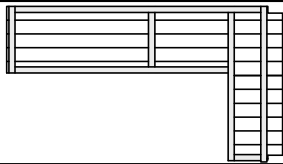
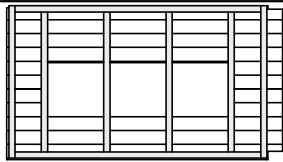

Pos	SPECIFICATION-STÜCKLISTE-NOMENCLATURE-ELEMENTI-ESPECIFICACIÓN "ELC16-2022"	Pcs	Profile (mm)	Length (mm)
AR31	Foundation- Fundament- Fondation- Fondazione- Vigas de cimentación- NAT 	10	32x40	1125
AR32	Foundation- Fundament- Fondation- Fondazione- Vigas de cimentación- NAT 	6	32x40	450
CoB2	Covering board- Deckbrett- Madrier de couverture- Tavola di copertura- Listón de cubierta 	2	70x19	1790
CoB1	Covering board- Deckbrett- Madrier de couverture- Tavola di copertura- Listón de cubierta 	2	70x19	1790
CoB3	Covering board- Deckbrett- Madrier de couverture- Tavola di copertura- Listón de cubierta 	2	70x19	1542
CoB4	Covering board- Deckbrett- Madrier de couverture- Tavola di copertura- Listón de cubierta 	2	70x19	1530
Det1	Detail- Detail- Detail- Dettaglio- Detalle 	1	16x16	564
Det2		1	16x16	880
PG1	Plexiglass- Plexiglas- Plexiglas- Plexiglas- Plexiglas 	1	1200x15	410
PG2	Plexiglass- Plexiglas- Plexiglas- Plexiglas- Plexiglas 	1	540x15	230
Rai1	Railing board- Geländer- Barre de rambarde- Tavola di ringhiera- Tabla de barandilla 	4	45x16	614
RoR1	Rafter- Sparre- Chevron- Trave- Cabrio 	3	44x95	1890
Sla1	Slat- Leiste- Baguette- Listello- Listón 	2	40x12	1240
Sla2	Slat- Leiste- Baguette- Listello- Listón 	2	40x12	580
Sla3	Slat- Leiste- Baguette- Listello- Listón 	2	40x12	450
Sla4	Slat- Leiste- Baguette- Listello- Listón 	2	40x12	270
SP1	Support brace- Stützleiste- Baguette de support- Listello di supporto- Listón de soporte 	2	45x25	360
WiB1	Window bars- Fenstersprossen- Grilles fenêtres- Finestra barre- Listones embellecedores 	2	40x10	370
WiB2	Window bars- Fenstersprossen- Grilles fenêtres- Finestra barre- Listones embellecedores 	4	40x10	190
FB1-1	Floor board- Fussbodenbrett- Madrier du plancher - Tavola pavimento- Tabla de suelo 	18	89x16	1960
TB3-1	Terrace board- Terrassenbrett- Madrier de terrace- Tavola terrazzo- Tabla de terraza- NAT 	6	95x16	1960
RB1-1	Roof board- Dachbrett- Madrier du toit- Tavola tetto- Tabla de tejado 	22	89x16	2200
Del-1	Door element- Türelement- Panneau du porte- Elemento di porta- Elemento puerta 	1	48x536	1420
EaE2-1	Eave edging- Dachrandbrett- Madrier en bordure du toit- Tavola bordo tetto- Tabla de valadizo 	2	16x120	2240

Pos	SPECIFICATION-STÜCKLISTE-NOMENCLATURE-ELEMENTI-ESPECIFICACIÓN "ELC16-2022"	Pcs	Profile (mm)	Length (mm)
FaB3-1	Facia board- Giebelblende- Écran frontal- Schermo frontone- Tabla de facia 	2	16x120	1894
Yar-1	Railing- Geländer- Rambarde- Ringhiera- Barandilla 	4	32x580	610
RE2-1	Roof edge reinforcement- Dachrandleiste- Baguette en bordure du toit- Rinforzo bordo tetto- Refuerzo borde tejado 	2	32x40	1870
Rel-1	Roof element- Dachelement- Panneau de toit- Elemento di tetto- Elemento tejado 	1	45x443	882
Wel-1	Wall element- Wandelement- Panneau du mur- Elemento di muro- Elemento pared 	1	48x989	1530
Wel-2	Wall element- Wandelement- Panneau du mur- Elemento di muro- Elemento pared 	1	48x980	1530
Wel-3	Wall element- Wandelement- Panneau du mur- Elemento di muro- Elemento pared 	1	48x810	1656
Wel-4	Wall element- Wandelement- Panneau du mur- Elemento di muro- Elemento pared 	1	48x810	1656
Wel-5	Wall element- Wandelement- Panneau du mur- Elemento di muro- Elemento pared 	1	48x810	1782
Wel-6	Wall element- Wandelement- Panneau du mur- Elemento di muro- Elemento pared 	1	48x810	1782
Wel-7	Wall element- Wandelement- Panneau du mur- Elemento di muro- Elemento pared 	1	48x1002	1775
Wel-8	Wall element- Wandelement- Panneau du mur- Elemento di muro- Elemento pared 	1	48x989	1775
WB1-1	Wind brace- Windbrett- Madrier contre le vent- Tavola vento- Tabla contra el viento 	2	16x45	1910



NB!

1.

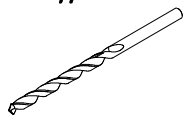

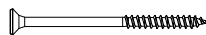

2.

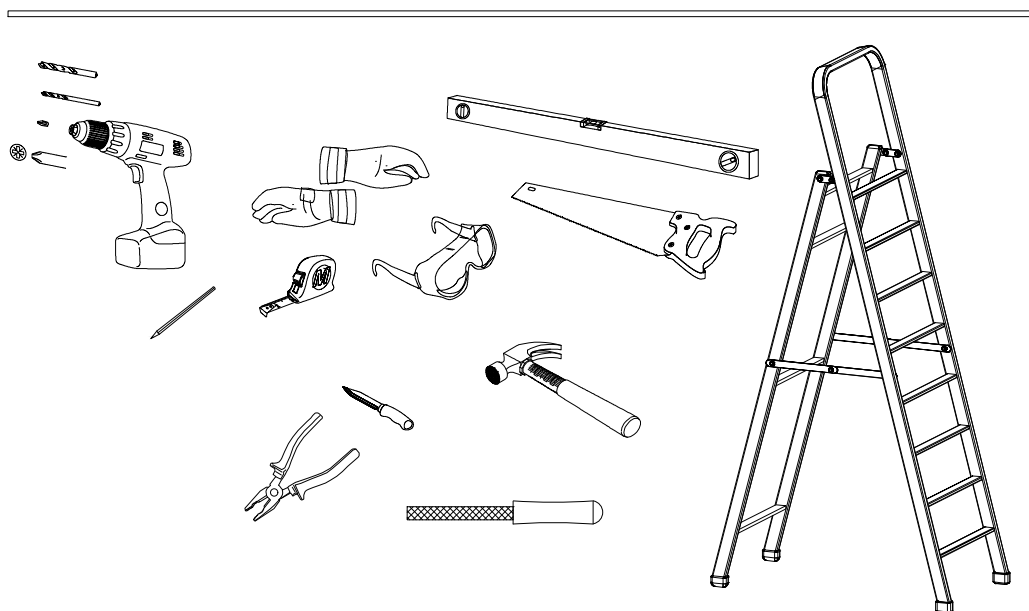
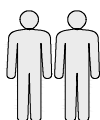
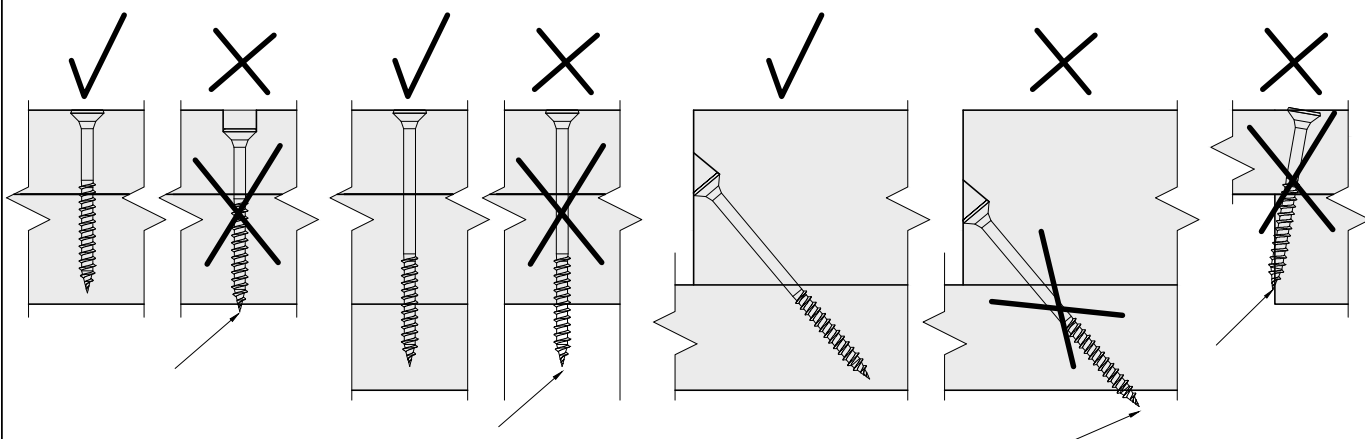

$\phi 1,5\text{mm}$	$\phi 3,0...4,0$
$\phi 2,0\text{mm}$	$\phi 4,5$





- PG1 1 pcs
- PG2 1 pcs
- Wel-8 1 pcs
- Del-1 1 pcs
- Sla1 2 pcs
- Sla2 2 pcs
- Sla3 2 pcs
- Sla4 2 pcs
- WiB1 2 pcs
- WiB2 4 pcs
- 3x12  12 pcs
- 3x20  4 pcs
- 4x25  28 pcs

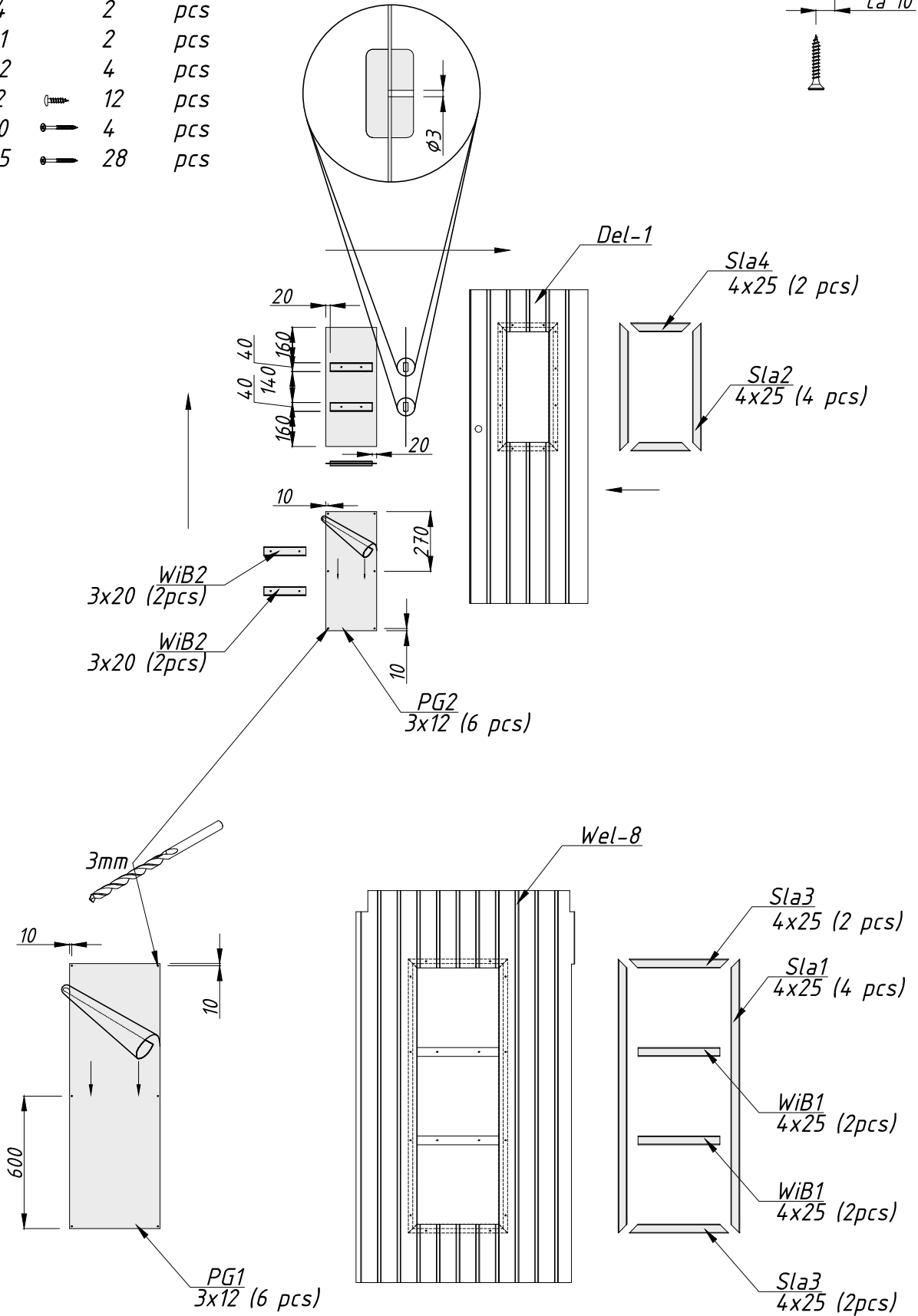
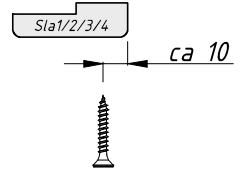
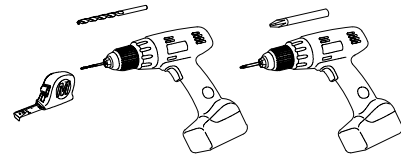
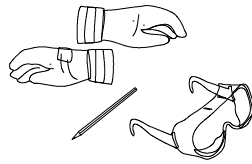

- AR31 10 pcs
- AR32 6 pcs
- 4,5x60 22 pcs

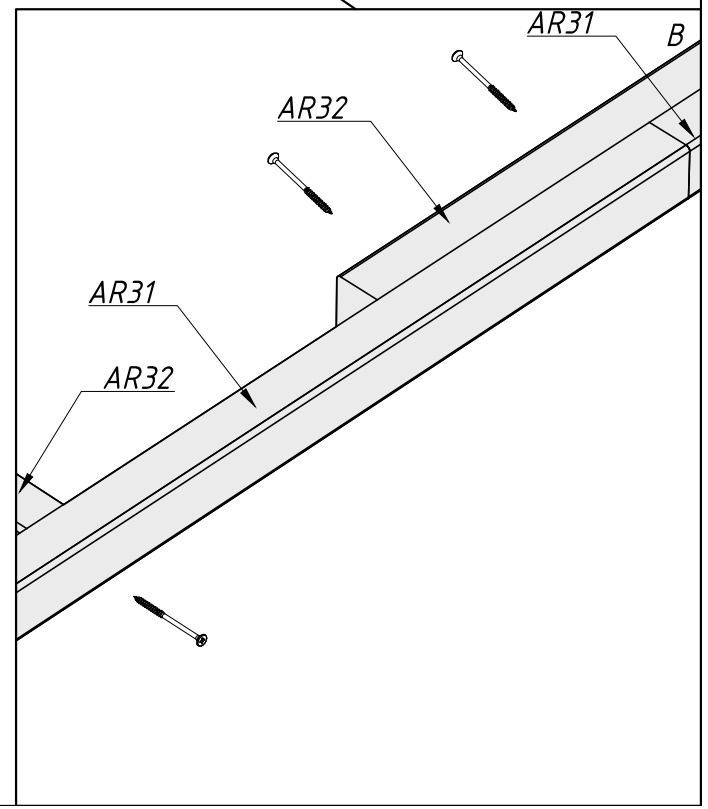
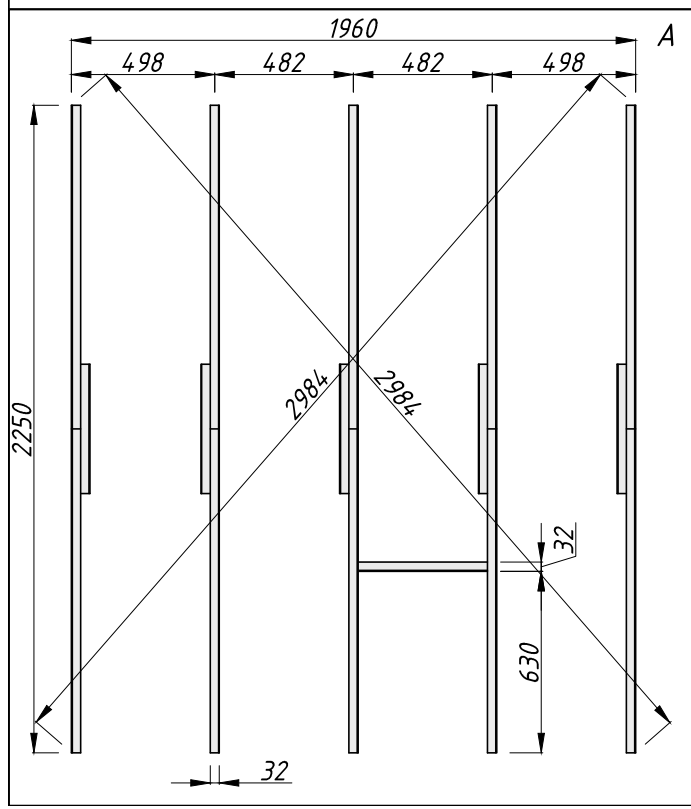
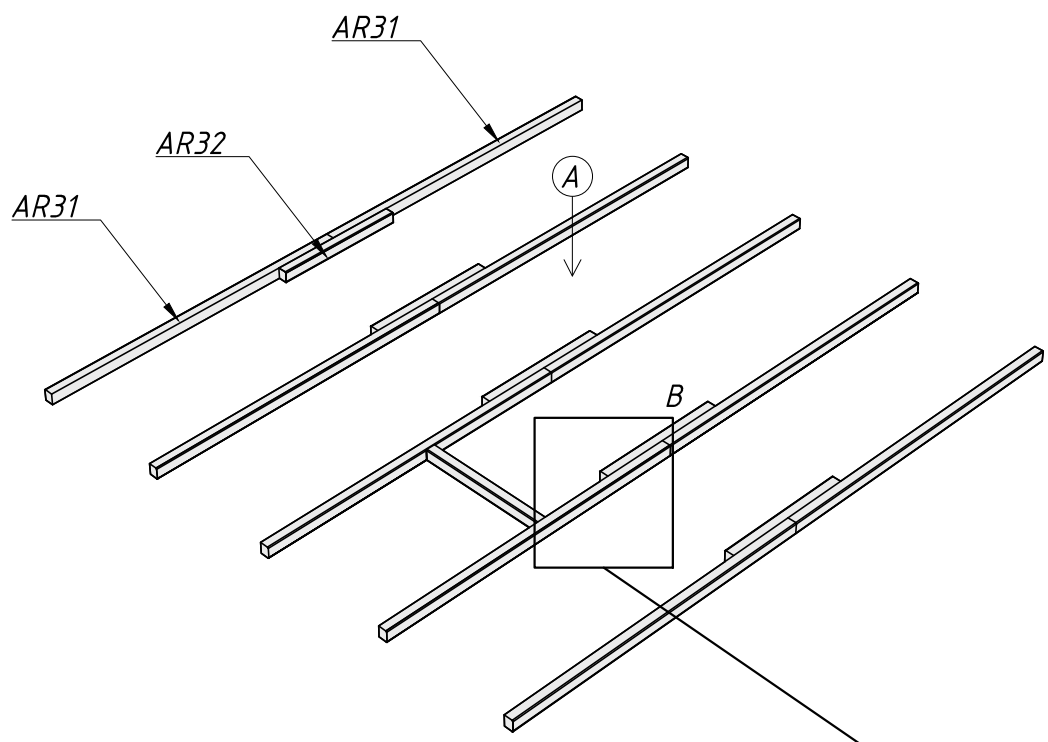
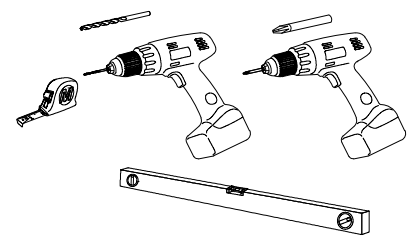
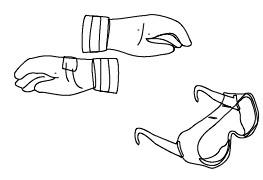

TB3-1	6	pcs
FB1-1	18	pcs
Det1	1	pcs
2,5x50	150	pcs

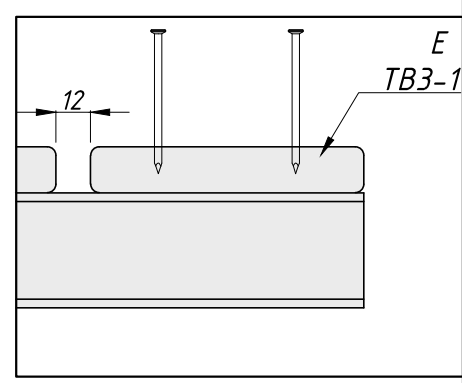
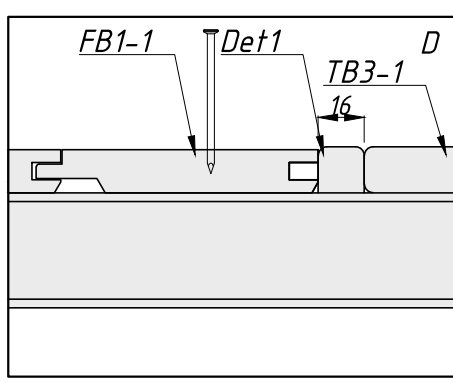
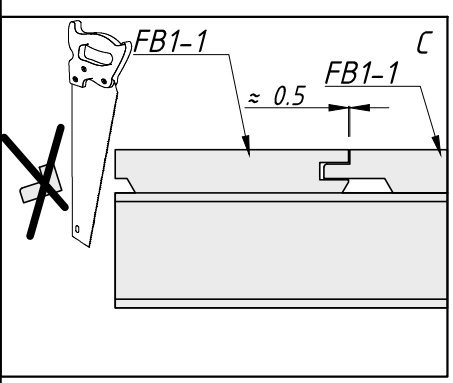
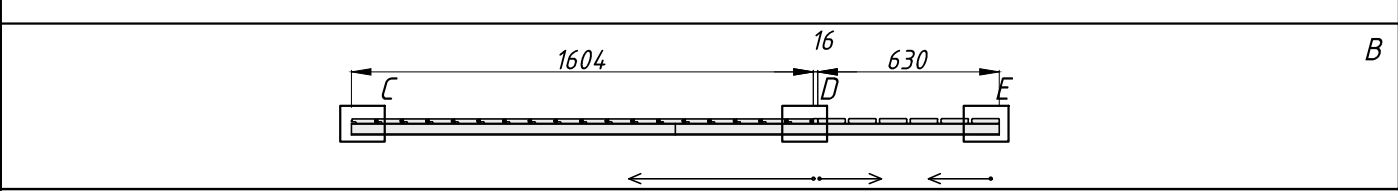
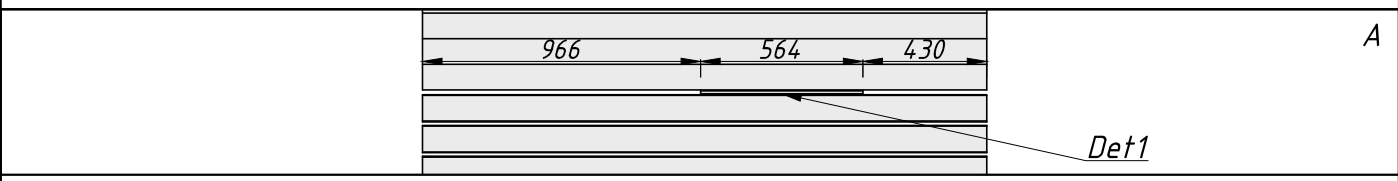
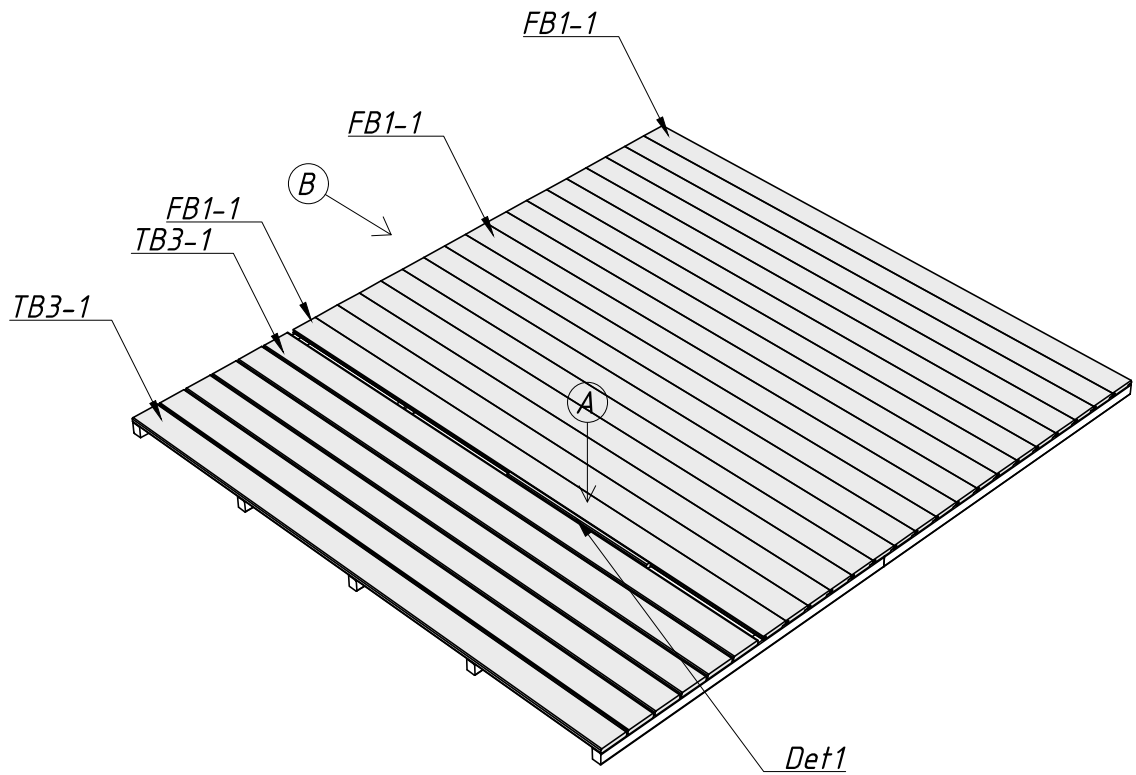
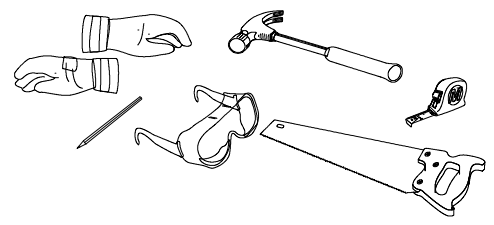

- Wel-1 1 pcs
- Wel-4 1 pcs
- 4,5x70 10 pcs

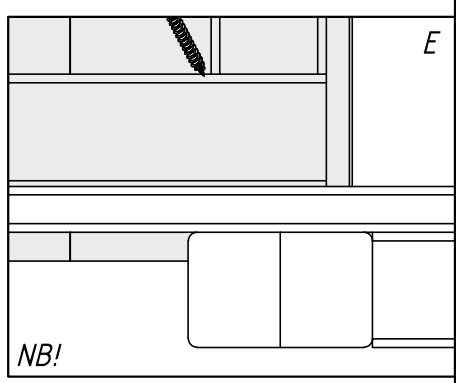
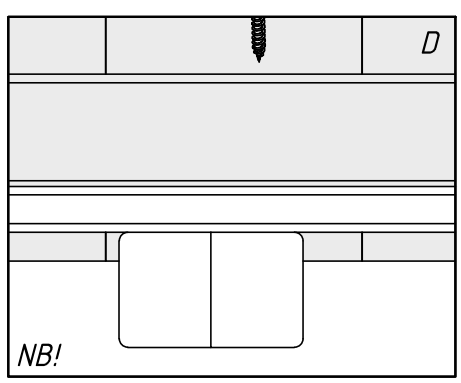
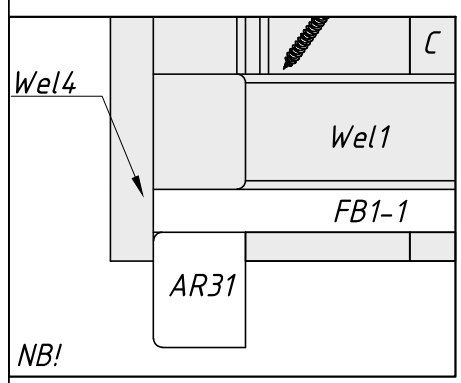
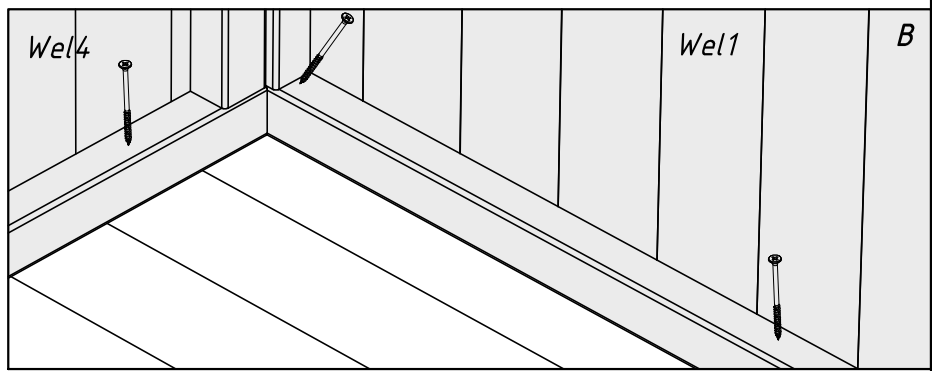
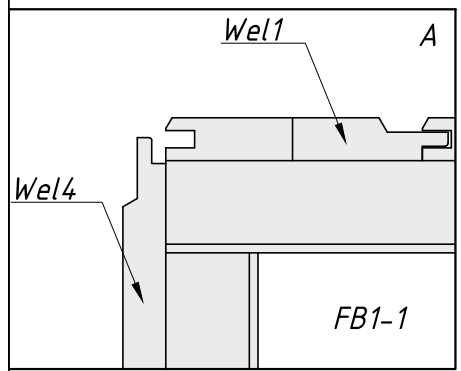
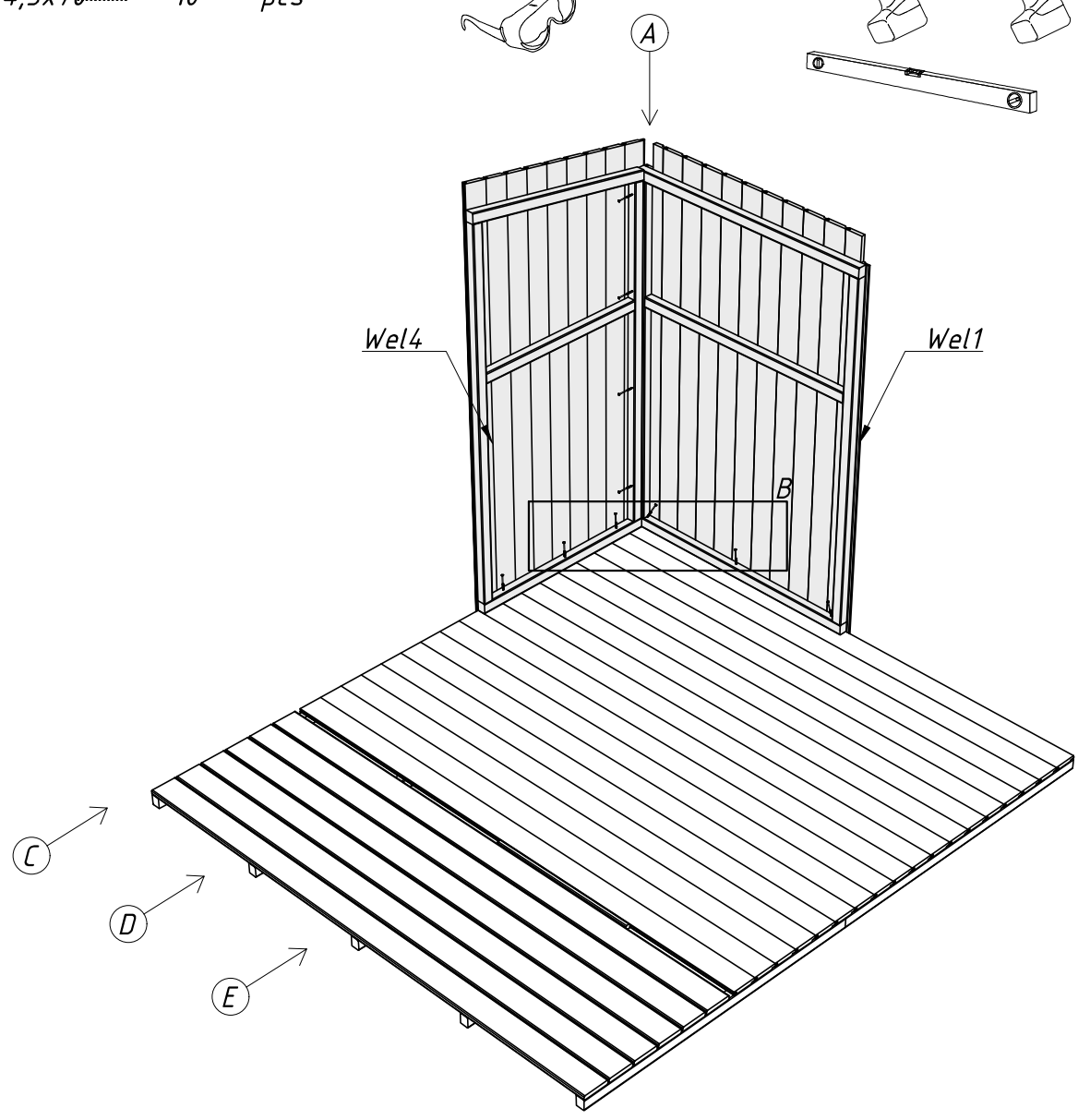
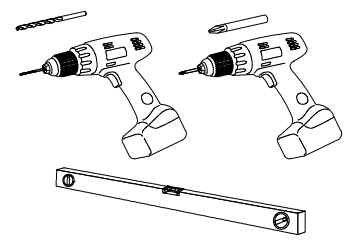
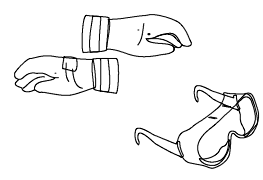

NB!

NB!

NB!

- Wel-2 1 pcs
- Wel-3 1 pcs
- Wel-5 1 pcs
- Wel-6 1 pcs
- Wel-7 1 pcs
- Wel-8 1 pcs
- Ⓜ 4,5x70 44 pcs

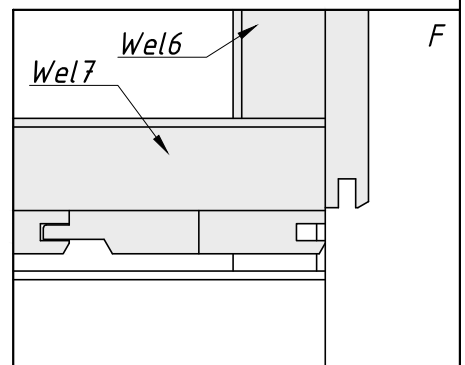
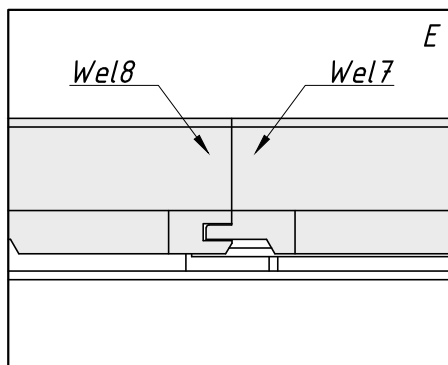
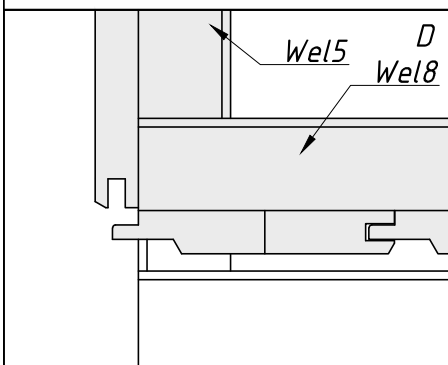
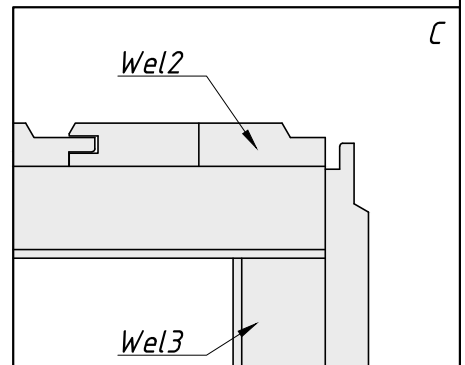
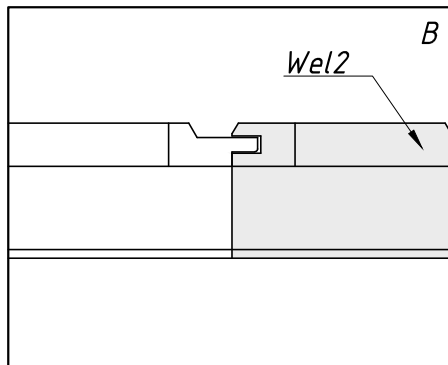
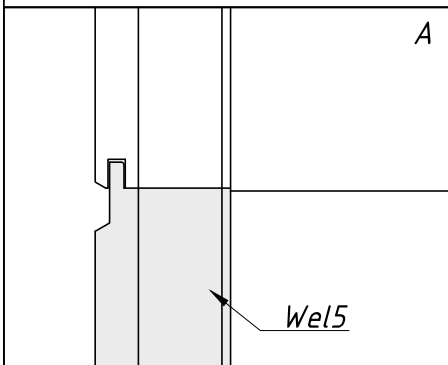
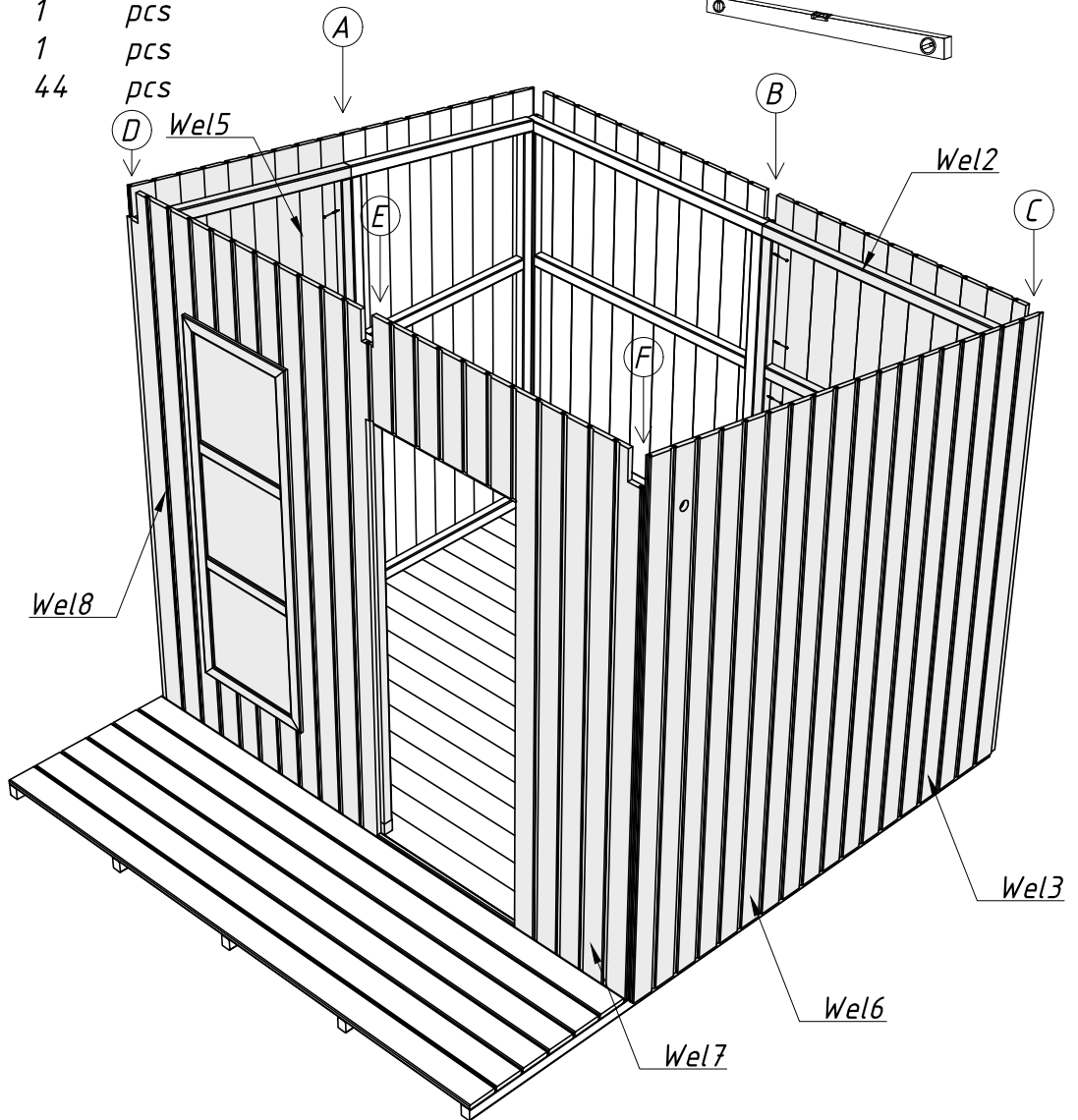
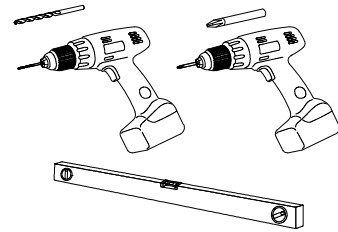
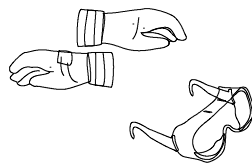

- RoR1 3 pcs
- 40x40x20 4 pcs
- 4,5x40 24 pcs
- 4,5x70 12 pcs

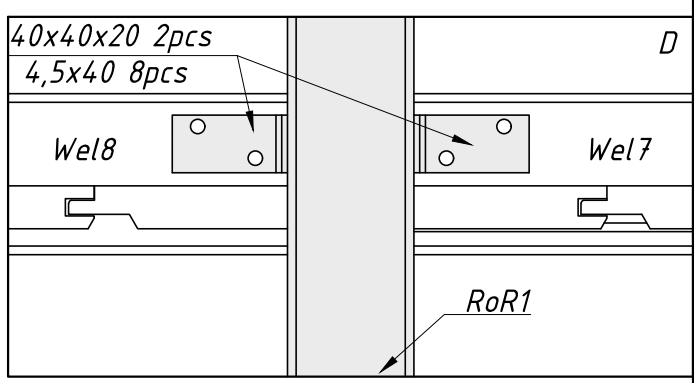
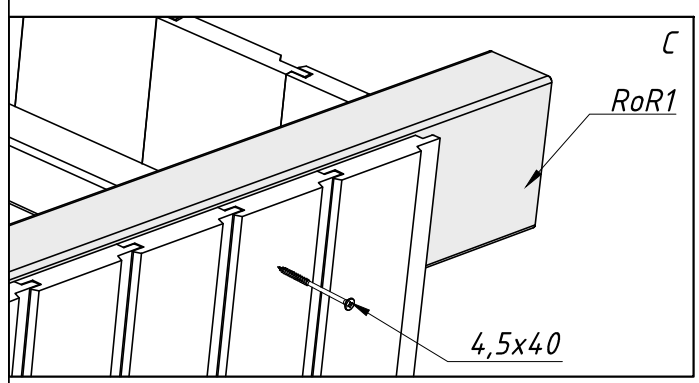
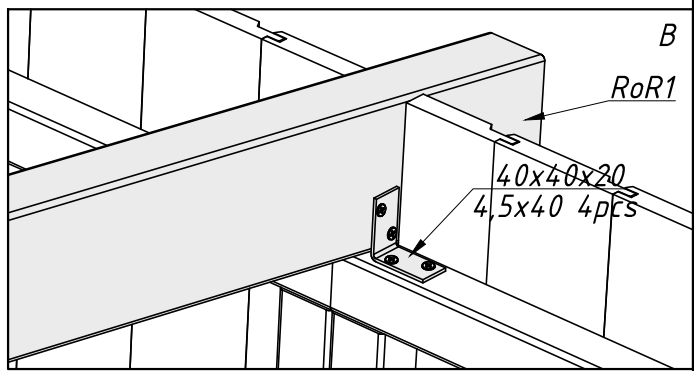
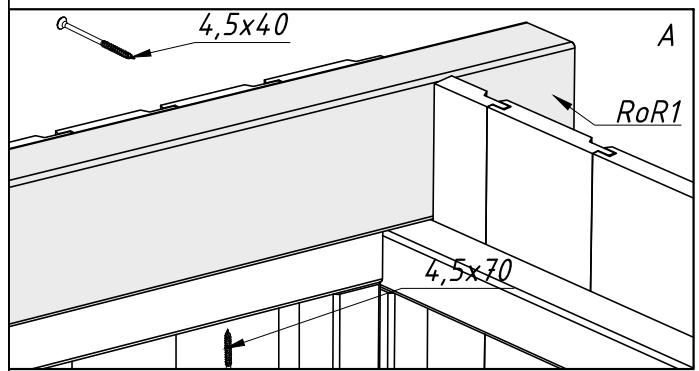
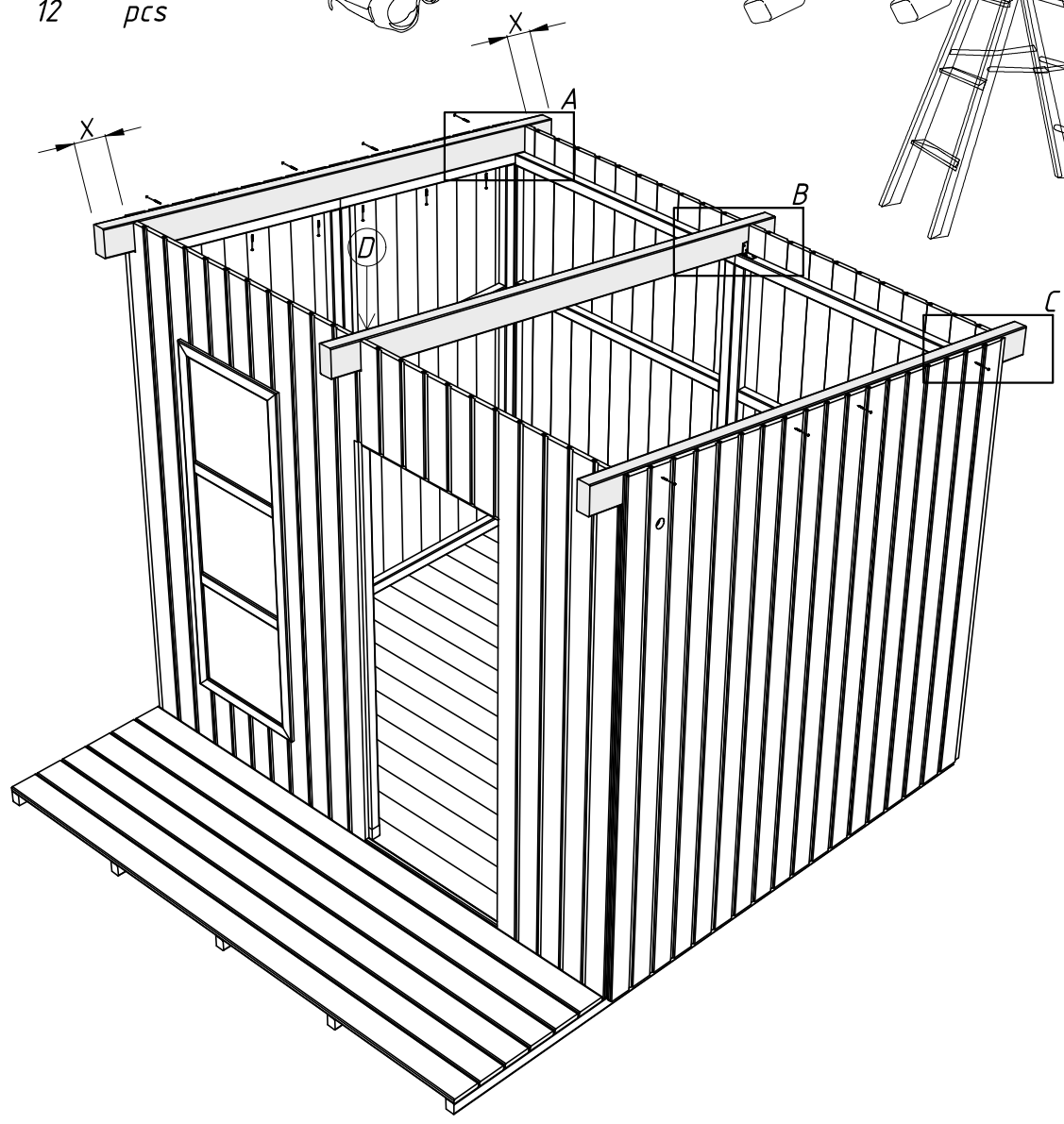
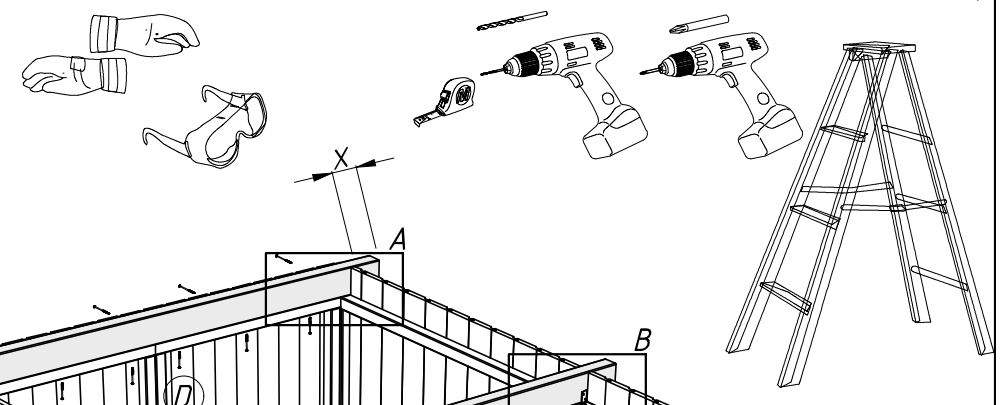

- RB1-1 22 pcs
- RE2-1 2 pcs
- 2,5x50 66 pcs
- 4,5x40 10 pcs

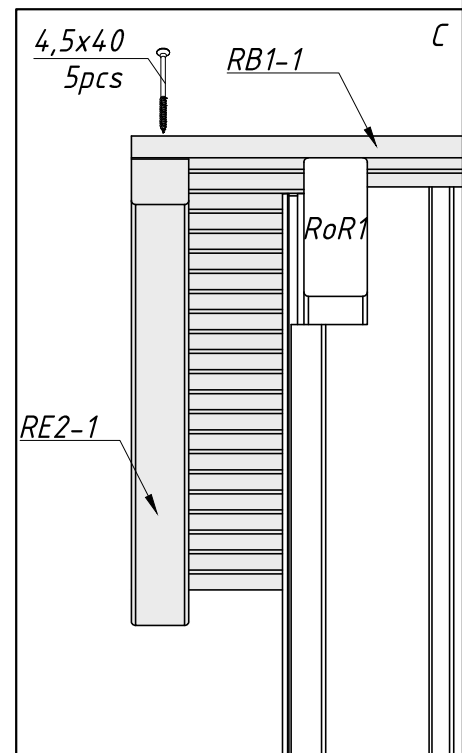
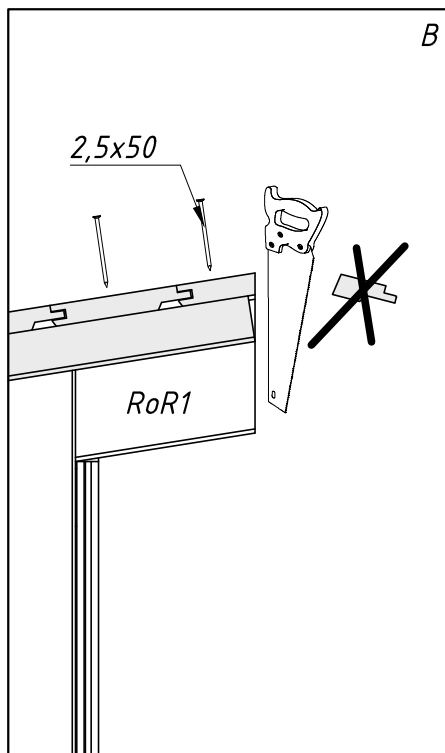
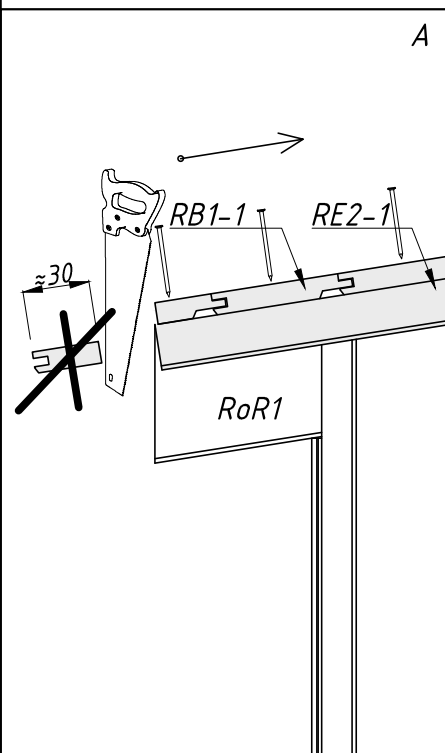
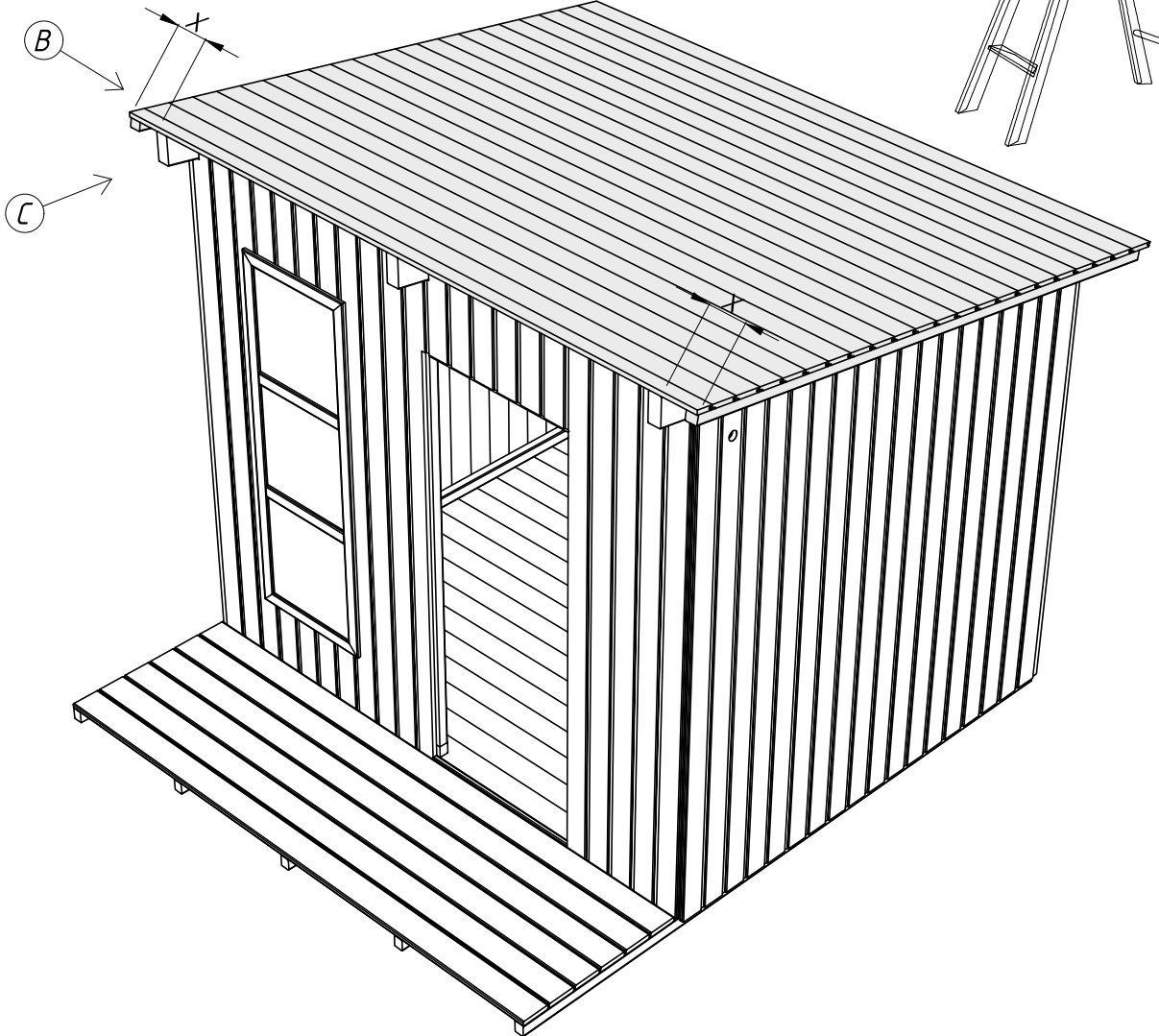
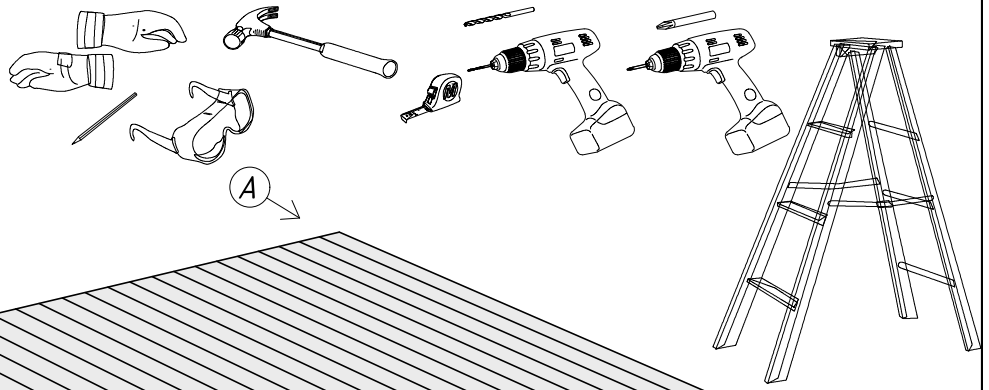

- CoB-1 2 pcs
- CoB-2 2 pcs
- CoB-3 2 pcs
- CoB-4 2 pcs
- ⌀4,5x50 40 pcs

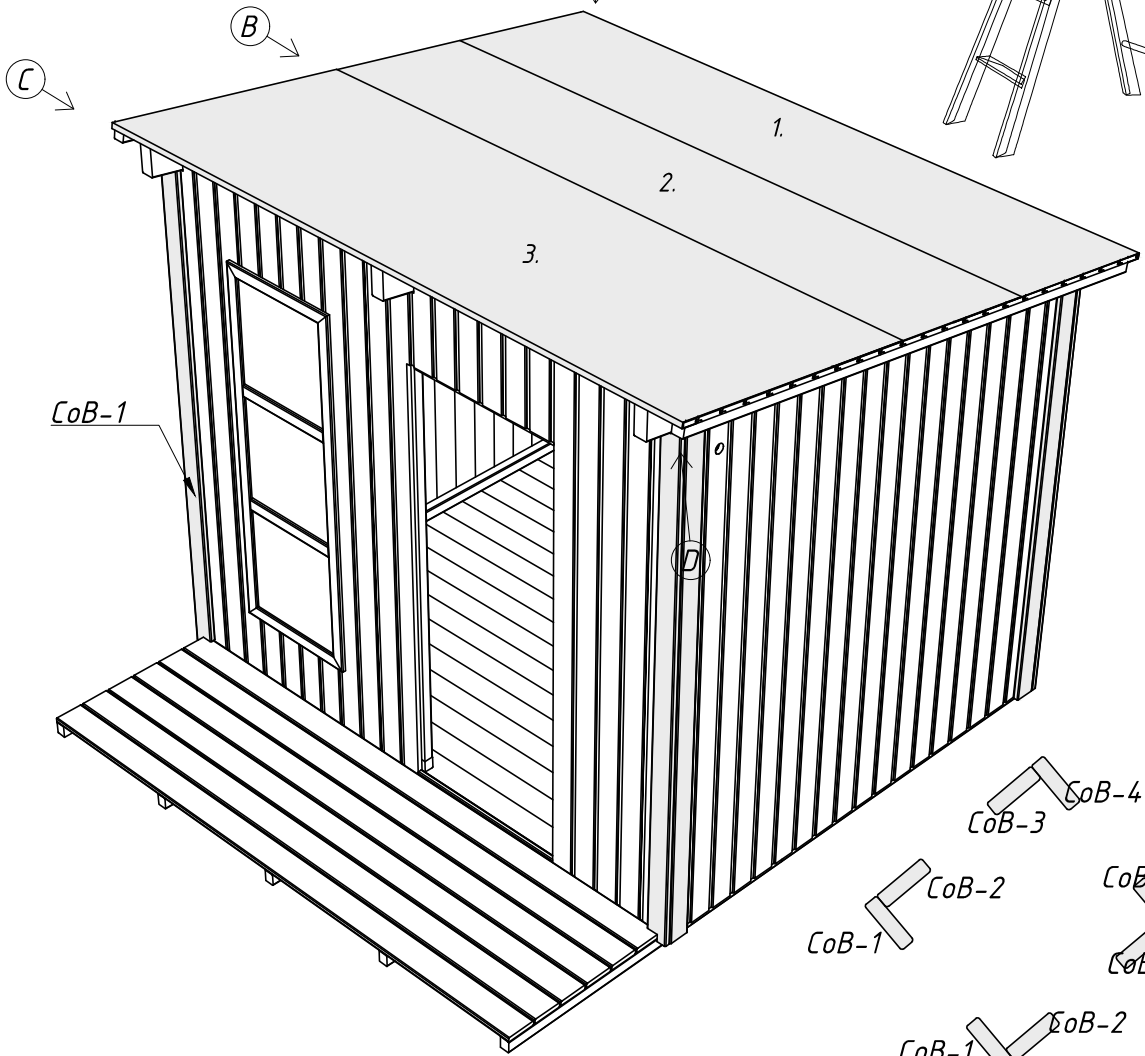
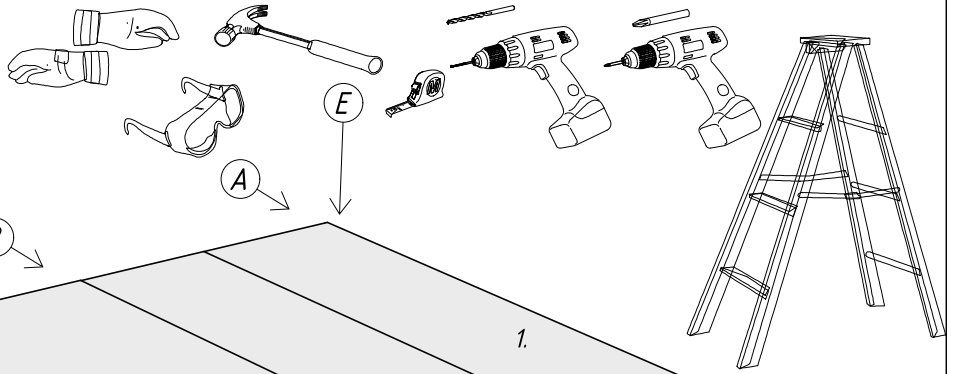

DE - Dachpappe nicht im Lieferumfang!  
 EN - Roofing felt not included!  
 ES - Material de cubierta no incluido!  
 FR - Toiture se sentait pas inclus!  
 IT - Copertura non si sentiva incluso!  
 NO - Takdekke ikke inkludert!  
 SW - Takpapp ingår ej!  
 FI - Kattoluopa ei sisälly pakettiin!  
 ET - Katusekafitematerjal ei sisaldu komplektis!  
 NL - Dakvilt is niet inbegrepen in het pakket!  
 LV - Jumta pape komplektā nav iekļautas!  
 LT - Stogo tolis į komplektą neįtrauktas!  
 PL - Okładzina dachowa nie wchodzi w skład zestawu!  
 DK - Tagmateriale medfølger ikke!  
 CZ - Krytinová rohož není zahrnuta v sadě!  
 PT - Não incluídos no kit: material para a cobertura de tetos.

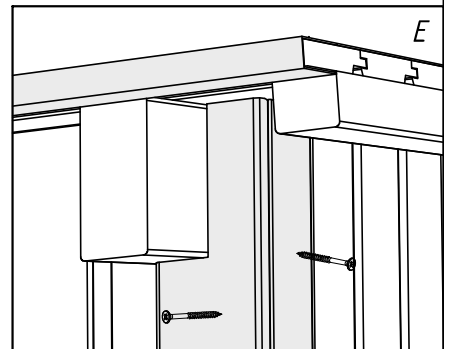
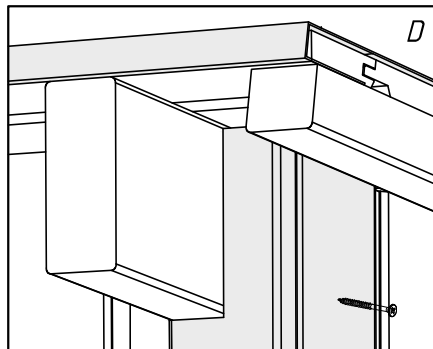
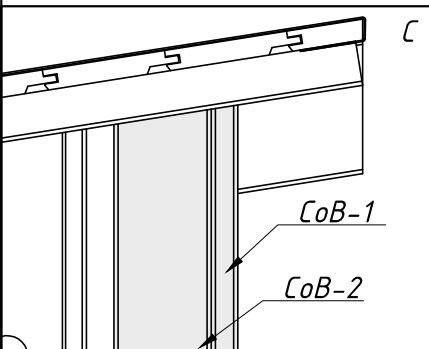
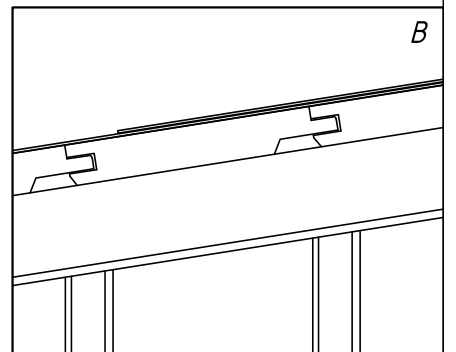
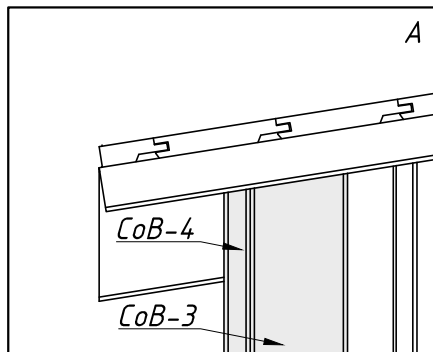

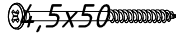

- EaE2-1 2 pcs
- FaB3-1 2 pcs
- WB1-1 2 pcs
-  1 Pcs
-  36 pcs

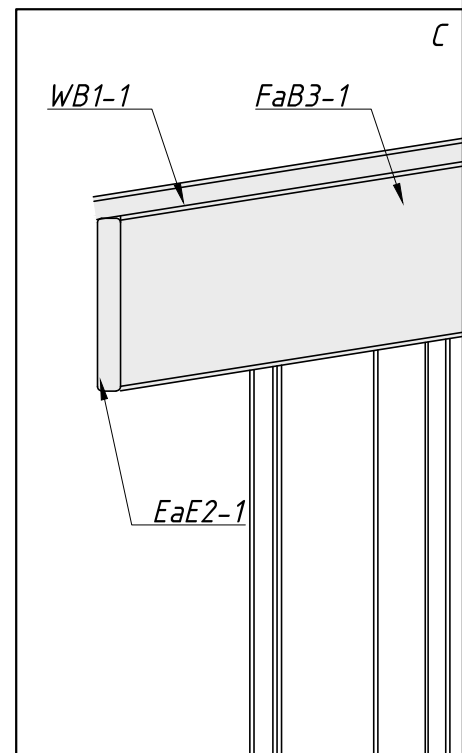
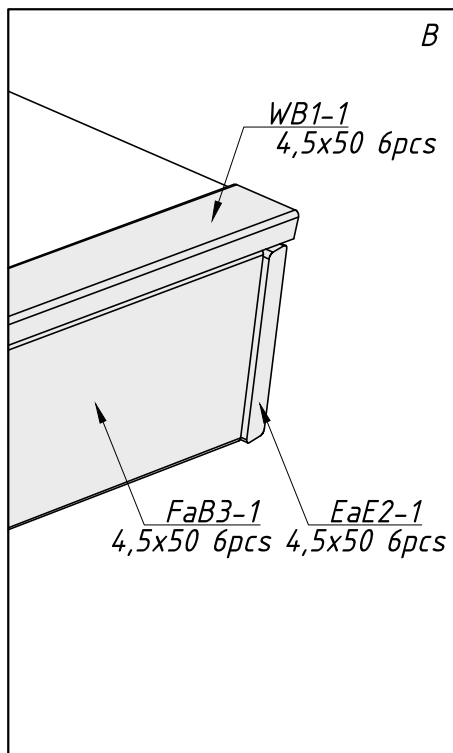
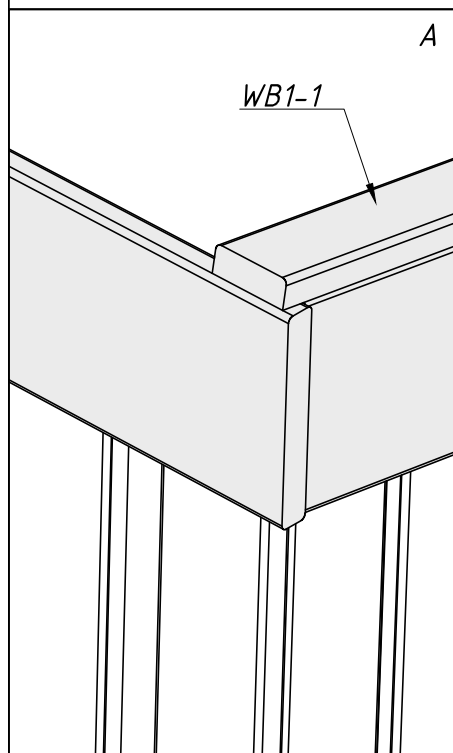
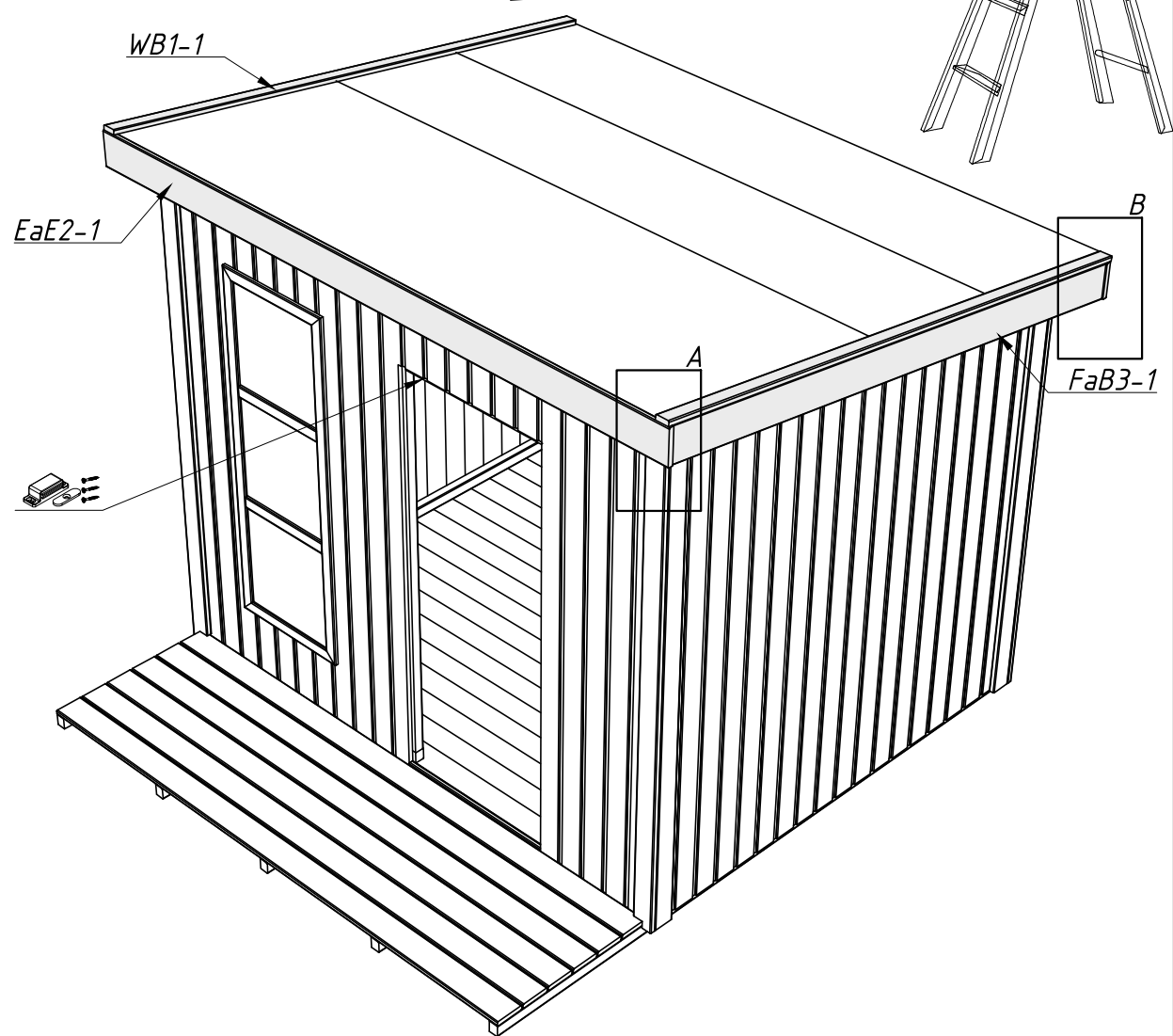
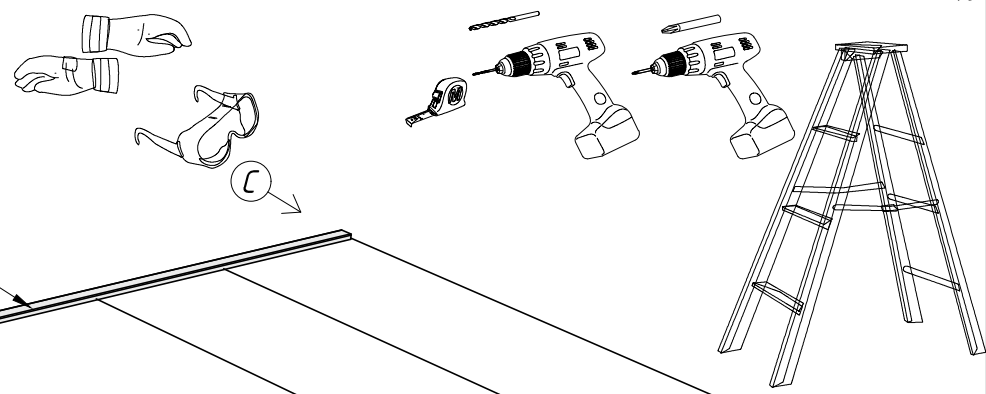

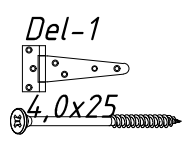

1 pcs  
2 pcs  
14 pcs

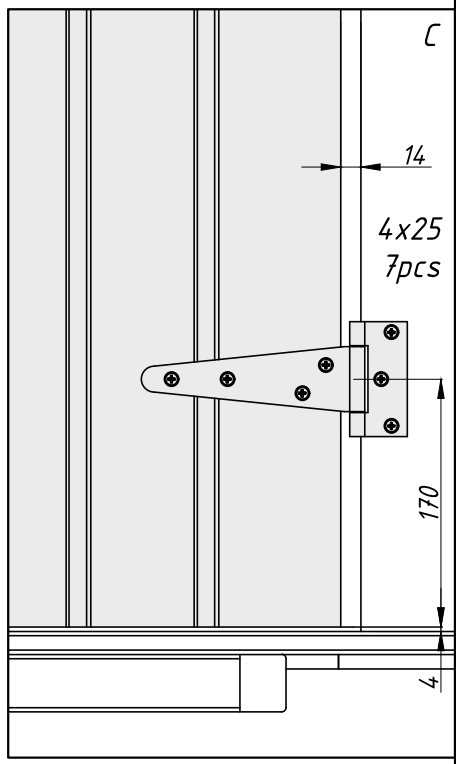
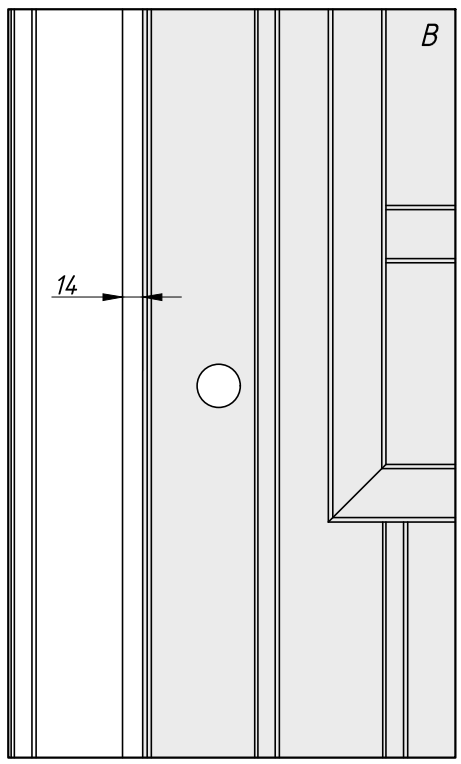
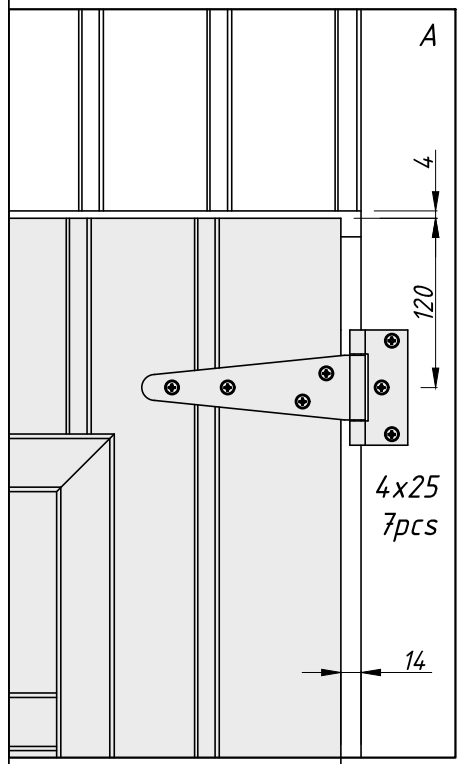
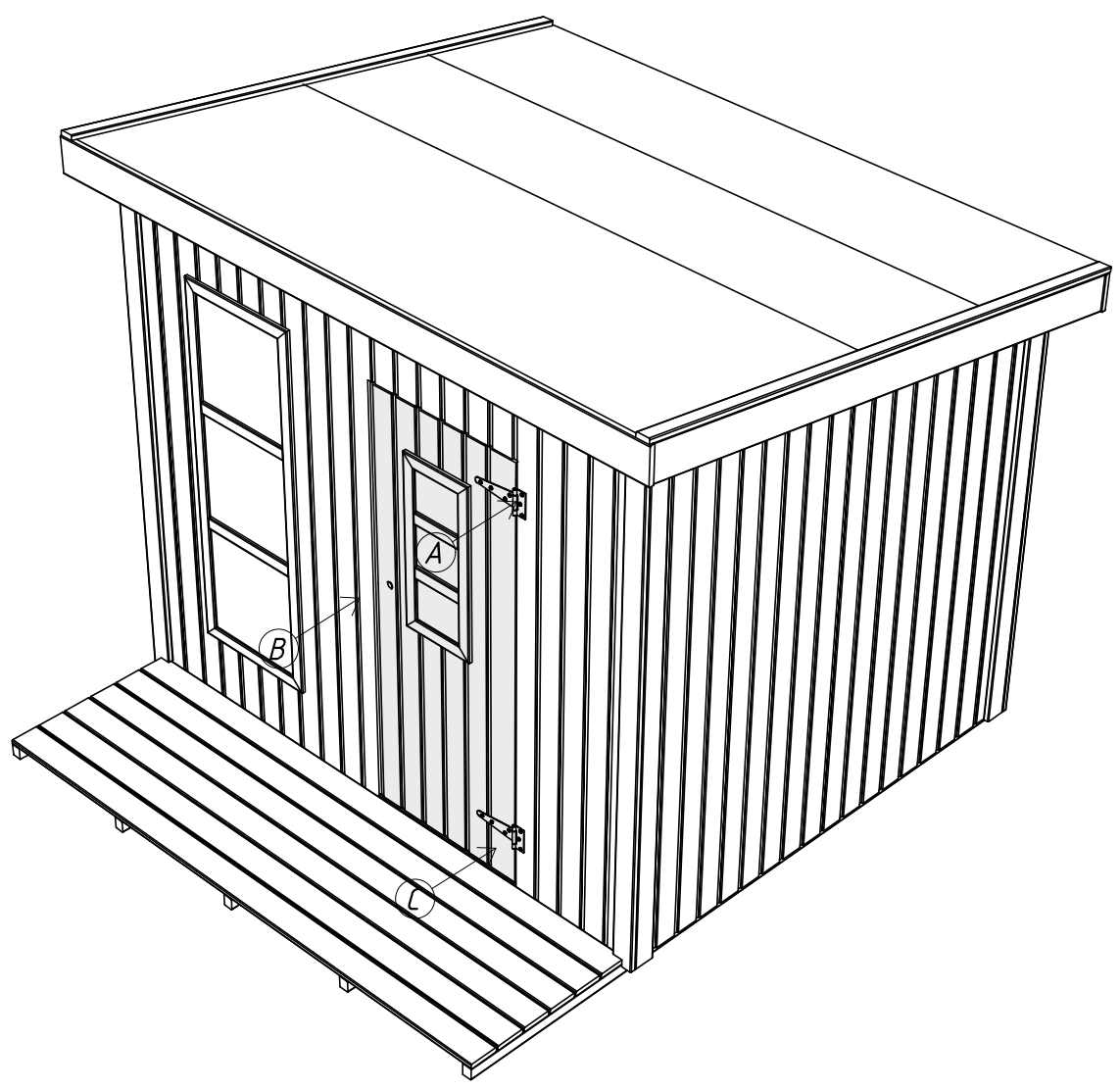
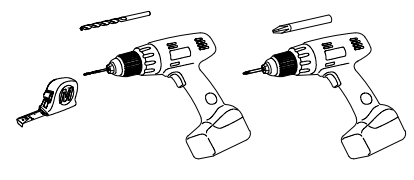
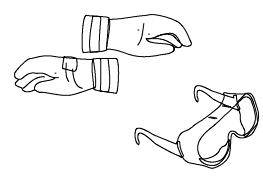

- Rel-1 1 pcs
- SP1 2 pcs
- 4x25 3 pcs
- 4,5x50 4 pcs
- 4,5x70 8 pcs

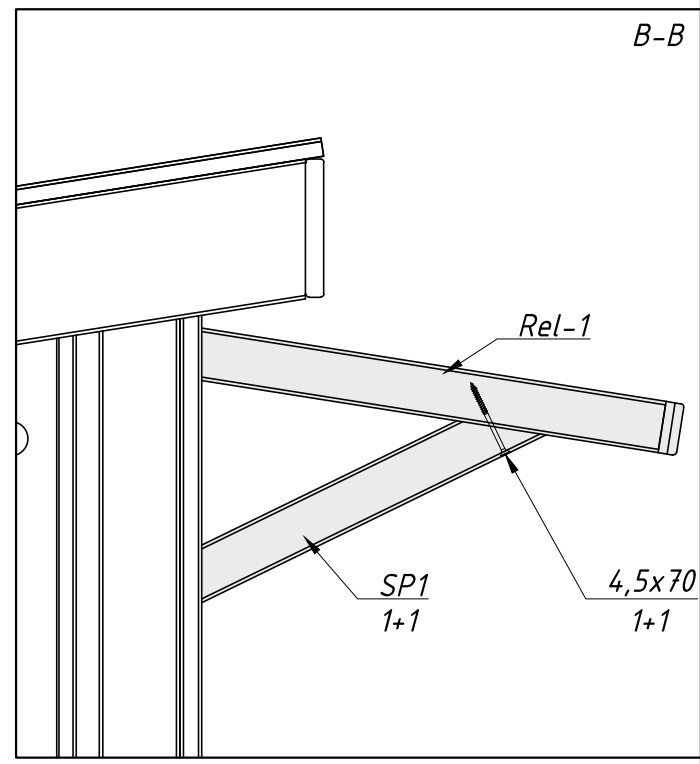
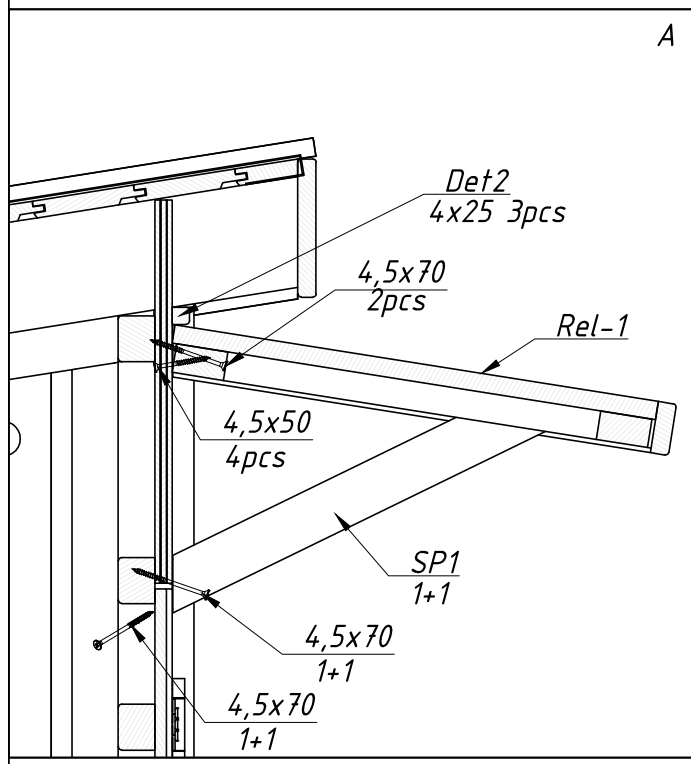
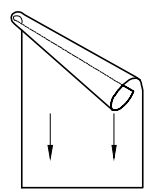
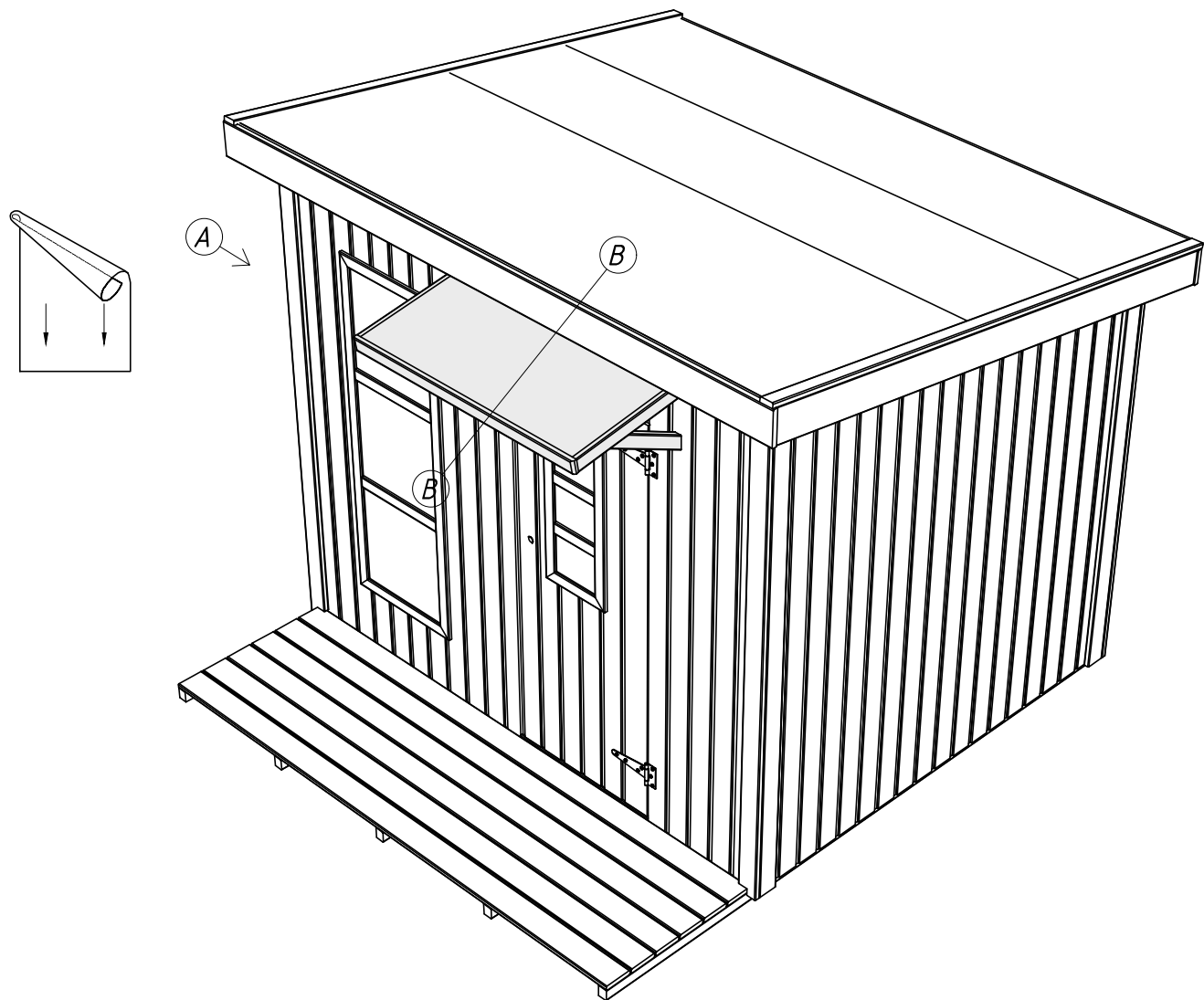
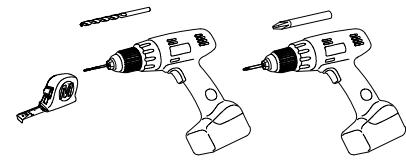
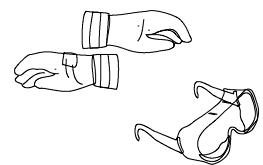

- Yar-1 4 pcs
- Rai1 4 pcs
- └ 2 pcs
- ⊕ 4x25 12 pcs
- ⊕ 4,5x50 12 pcs
- ⊕ 4,5x70 18 pcs

