



Assembly, installation and maintenance manual

APACHE COUNTY 1 PLAYHOUSE

Width 176 x Depth 176 cm
Wall thickness 19 mm



WARNINGS:

Not suitable for children under 3 years. Risk of crushing.

To be used under the direct supervision of an adult. Risk of falling.

Only for outdoor domestic use.

Keep away from fire.

The product is supplied disassembled. Adult assembly required.

Intended for children from 3 to 14 years (max 50 kg/user).

Attention!

- It is not allowed to climb on the barriers and roof of the assembled house.
- Caution. Wooden details can contain slight torn grain or sharp ends and edges.
- The product is designed for simultaneous use by up to 6 persons.
- The supplied kit does not include any roof cover material. Before you begin using the house, you must obtain a suitable roof cover material (bitumen shingles or rolls) and install it in accordance with the manufacturer's instructions! It is not recommended to leave the house without a roof cover in the rain or it will void the warranty!
- The product is delivered unfinished.

1 Assembly manual



Dear client,

We are glad that you have decided in favour of our garden house!

Please read the assembly manual carefully before proceeding with the house installation! You will thus avoid problems and will not waste time.

Recommendations:

- Keep the house package until its complete assembly in a dry place, but not in direct contact with the ground, protected from weather conditions (moisture, the sun, etc.). Do not keep the house package in a heated room!
- Assemble the product on the smooth surface at least 2m from any construction or barrier such as fence, garage, house, above situated tree branches, clotheslines and electric cables.
- When selecting the garden house location, make sure that the house will not be subjected to extreme weather conditions (areas of strong snowfall or winds); otherwise you should attach the house (for instance, with anchors) to the subsoil.
- Since the foundation joists are in constant contact with the ground they must be treated with a special wood preservative. Consult a specialist regarding paints suitable for unprocessed softwood and follow the paint manufacturer's instructions.



Warranty

Your house is made from high quality fir and delivered in the natural (unprocessed) form. If, despite our thorough inspection, you should have complaints, please submit the filled out control sheet and purchase invoice to the product seller.

ATTENTION: Please be sure to keep the documentation accompanying the house package! The control sheet includes the control number of the house. We can only review complaints if you submit the control number of the house to the seller!

The warranty does not cover:

- Peculiarities of wood as a natural material
- Wooden details already painted (processed with a wood preservative)
- Wooden details containing whole branches that do not endanger the stability of the house
- Colour tone variations caused by wood structure differences that do not influence wood lifetime
- Wooden details containing (caused by drying) small cracks/gaps that do not pass through and do not influence the structure of the house
- Twisted wooden details if they can nevertheless be installed
- Roof and floor boards that may have on their concealed surfaces some non-planed areas, colour differences and waning
- Complaints resulting from an incompetent manner of the installation of the house or the house subsiding due to an incompetently made foundation
- Complaints caused by introducing self-initiative changes to the house, such as the deformation of wooden details and doors/windows due to an incompetent manner of wood processing; the attachment of storm braces too rigidly, doorframes being screwed onto wall logs, etc.

The complaints covered by the warranty are satisfied to the extent of replacing the deficient/faulty material. All other demands will be excluded!



Garden house painting and maintenance

Wood is a natural material, growing and adapting depending on weather conditions. Large and small cracks, colour tone differences and changes, as well as a changing structure of wood are not errors, but a result of wood growing and a peculiarity of wood as a natural material.

Unprocessed wood becomes greyish after having been left untouched for a while, and can be turn blue and become mouldy. To protect the wooden details of your garden house, you must immediately process them with a wood preservative.

Attention! **The house is supplied without elaborative workmanship. To reduce fire hazard you should use paints or impregnation substances that prevent fire from spreading! Use water-based paints and impregnation substances and avoid solvent-based products!**

Consult a specialist regarding paints suitable for unprocessed softwood and follow the paint manufacturer's instructions.

It is not allowed to cover the product with lacquer or paint on which surface the flame spread rate is higher than 20mm/s.

When painting, use high quality tools and paints, follow the paint application manual and manufacturer's safety and usage instructions. Never paint a surface in strong sunlight or rainy weather.

After the house assembly is completed, we recommend for the conclusive finishing a weather protection paint that will protect wood from moisture and UV radiation.

- In lengthy periods of dry weather wood can shrink and the screw/bolt spots attachments can become weak. Conduct regular checks and tighten the screws/bolts as necessary (no less frequently than 6 month)! Otherwise the product may become dangerous.
- The suitability of the base material, corrosion of accessories and rotting of wooden parts should be checked once a year. Moving parts must be oiled and worn and/or defective parts should be replaced with parts provided by the manufacturer.
- Be especially attentive when checking barrier and door attachments.
- It is recommended to inspect the house thoroughly once in a year. Regular painting of the house will prolong its useful life substantially.
- You should also check the condition of the roof to discover any leaks as early as possible. Eliminate leaks as you find them to prevent rainwater from damaging the roof and other wooden parts of the house.

Attention! **For repairing the product use only identical details. The specification of the components can be found from the documentation accompanying the house package.**



We wish you total success with the garden house installation and much joy with this house for many years to come!

2 Installation manual

Tools and preparation of components

To assemble the garden house, you will need the following tools:



assembly aid



ladder



hammer



water-level



screwdriver



saw



knife



measuring tape



pliers



set of drill



file



adjustable spanner



pencil







ADVICE: To avoid possible injuries from splinters, we recommend to wear the corresponding protective gloves during the assembly process. To protect your eyes from sawdust, we recommend to wear protective glasses during the assembly process.

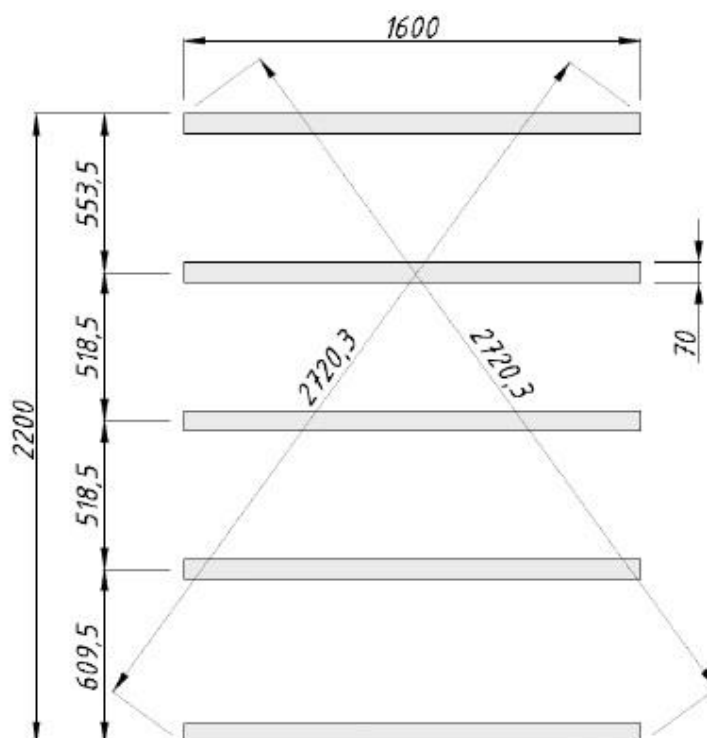

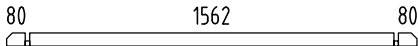
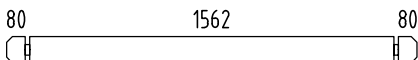
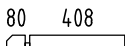
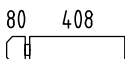
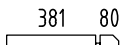

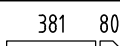
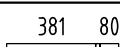
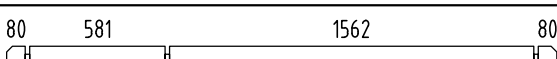
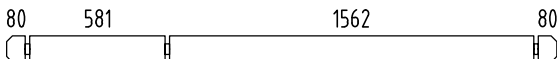
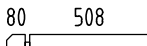
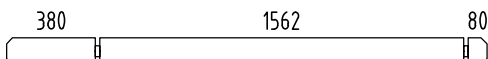
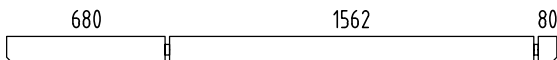
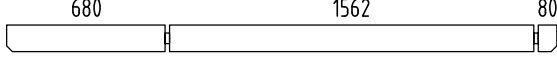
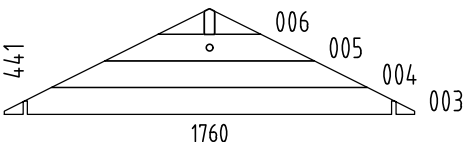
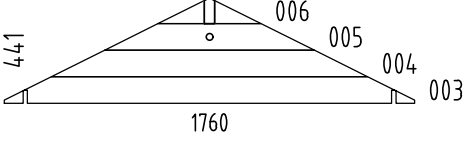
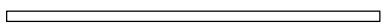

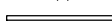



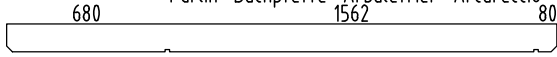



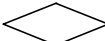



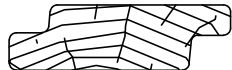
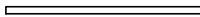

Before screwing, please drill hole in order to avoid cracks in the wood.

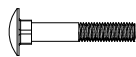
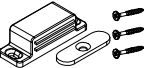
All projecting screws and sharp edges must be panned smooth immediately after installation to avoid potential injuries.

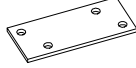
Level the ground and install the foundation joists according to the drawing below:

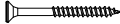

Pos	SPECIFICATION-STÜCKLISTE-NOMENCLATURE-ELEMENTI-ESPECIFICACIÓN FRC19-1824FSC	Pcs	Profile (mm)	Length (mm)
000		1	19x114	250
001		1	19x57	1760
002		25	19x114	1760
007		2	19x57	507
008		24	19x114	507
009		2	19x57	480
010		4	19x114	179
011		2	19x114	120
012		2	19x114	480
013		2	19x57	480
014		2	19x114	2360
015		2	19x114	2360
016		10	19x114	607
017		2	19x114	2060
018		1	19x120	2360
019		1	19x120	2360
W1-1		1	19x441	1760
W2-1		1	19x441	1760
AR31	Foundation- Fundament- Fondation- Fondazione- Vigas de cimentación- NAT 	5	70x45	1600
Rai2	Railing board- Geländer- Barre de rambarde- Tavola di ringhiera- Tabla de barandilla 	2	19x70	515
Rai1	Railing board- Geländer- Barre de rambarde- Tavola di ringhiera- Tabla de barandilla 	2	19x70	475
SP1	Support brace- Stützleiste- Baguette de support- Listello di supporto- Listón de soporte 	4	19x19	461
SP2	Support brace- Stützleiste- Baguette de support- Listello di supporto- Listón de soporte 	4	19x19	360

Pos	SPECIFICATION-STÜCKLISTE-NOMENCLATURE-ELEMENTI-ESPECIFICACIÓN FRC19-1824FSC	Pcs	Profile (mm)	Length (mm)
UP1	U-profile board- U-Profilleiste- Baguette profilée en U- Listello profilo ad U- Listón de perfil U 	2	45x55	325
PR1	Purlin- Dachpfette- Arbalétrier- Arcareccio- Vigueta de tejado 	1	44x120	2360
FB1-1	Floor board- Fussbodenbrett- Madrier du plancher - Tavola pavimento- Tabla de suelo 	18	89x16	1557
TB3-1	Terrace board- Terrassenbrett- Madrier de terrace- Tavola terrazzo- Tabla de terraza- NAT 	16	95x16	575
RB1-1	Roof board- Dachbrett- Madrier du toit- Tavola tetto- Tabla de tejado 	54	89x16	1110
Dia-1	Diamond- Deckbrett- Madrier- Tavola di copertura- Rombo 	2	19x120	217
FaB9-1	Facia board wavy-Giebelblende.geschwun- gen-Écran frontal.arqué-Schermo frontone.curvo- Tabla de facia ondulada 	4	16x120	1130
FIB2-1	Floor beading- Fussbodenleiste- Baguette du plancher- Listello pavimento- Listón de suelo 	4	19x19	1620
RE1-1	Roof edge reinforcement- Dachrandleiste- Baguette en bordure du toit- Rinforzo bordo tetto- Refuerzo borde tejado 16x45 	2	16x45	2360
SiS6-1	Side slat - Randleiste - Baguette en bordure - Listello bordo 6 	2	28x95	780
Sla20-1	Slat- Leiste- Baguette- Listello- Listón 	1	16x19	746
Sla20-2	Slat- Leiste- Baguette- Listello- Listón 	1	16x19	800
StB1-1	Storm brace- Sturmleiste- Protection contre le vent- Antivento- Protector contra tormentas 	4	25x45	1460
WB1-1	Wind brace- Windbrett- Madrier contre le vent- Tavola vento- Tabla contra el viento 	4	16x45	1130
Fim	-Fixing kit- Befestigungsset- Moyens de fixation- Materiale di fissaggio- Kit de fijación 	1		
QPUP0 8x50Zn	Bolt -Schloss-schraube -Boulon- Bullone- Perno- M8x50mm PUP0 	8	M8	50
QMSul gur46 x15x13	Magnetic stopper- Magnetverschluss- Bloc magnétique- Fijador magnético- Fermo magnetico 	1	15x13	46
QNA2 2x50Zn	Nail- Nagel- Clou- Chiodo- Clavo- 2.2x50mm 	260	∅2,2	50
QNLP2 5x60Zn	Nailing plate- Nagelplatte- Connecteur métallique- Piastra connettore- Placa del clavo 57x25x2 	4	25x2	57
QMU8 kybar lukk	Nut- Schraubenmutter- Écrou- Dado- Tuerca- M8mm- QMU8kybarlukk 	8	M8	14
QKR3 5x35Zn	Screw- Schraube- Vis- Vite- Tornillo- 3.5x35mm 	50	∅3.5	35
QKR3 x20Zn	Screw- Schraube- Vis- Vite- Tornillo- 3x20mm 	8	∅3.0	20
QKR3 x30Zn	Screw- Schraube- Vis- Vite- Tornillo- 3x30mm 	52	∅3.0	30
QKR4 5x50Zn	Screw- Schraube- Vis- Vite- Tornillo- 4.5x50mm 	30	∅4.5	50
QKR4 5x70Zn	Screw- Schraube- Vis- Vite- Tornillo- 4.5x70mm 	26	∅4.5	70

NB!

1.

2.

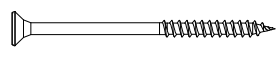
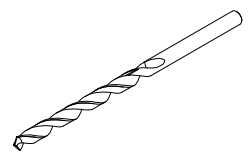

$\phi 1,5mm$	$\phi 3,0...4,0$
$\phi 2,0mm$	$\phi 4,5$
$\phi 3,0mm$	$\phi 5,0$

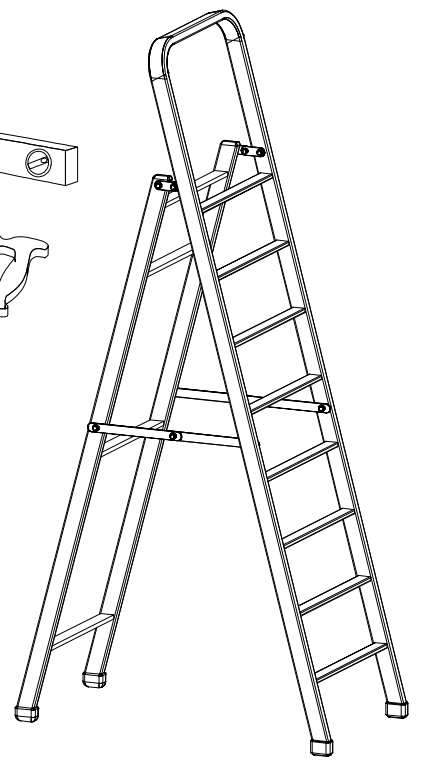
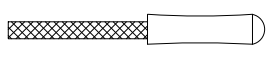
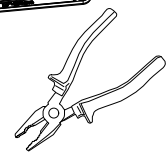
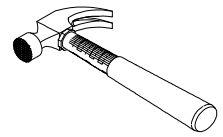
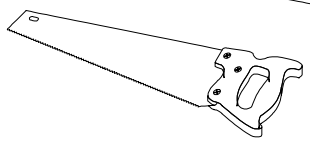
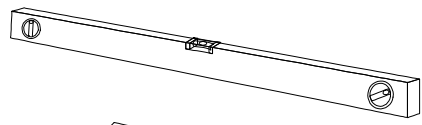
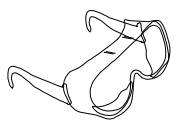
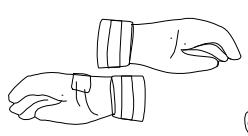
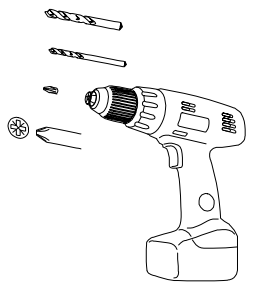
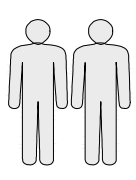
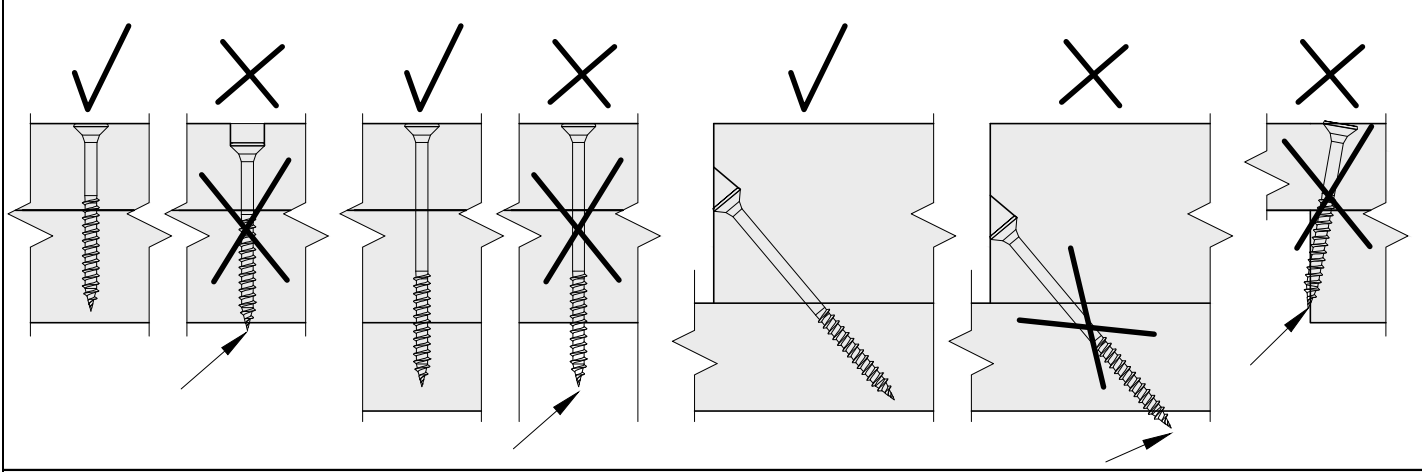
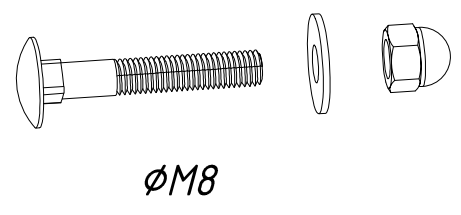
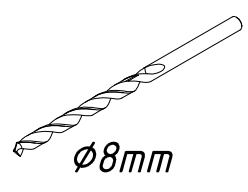

- AR31 -5pcs
- 001 -1pcs
- 007 -2pcs
- 009 -2pcs
- $\phi 4,5 \times 70$ -6pcs
- $\phi 5 \times 90$ -4pcs

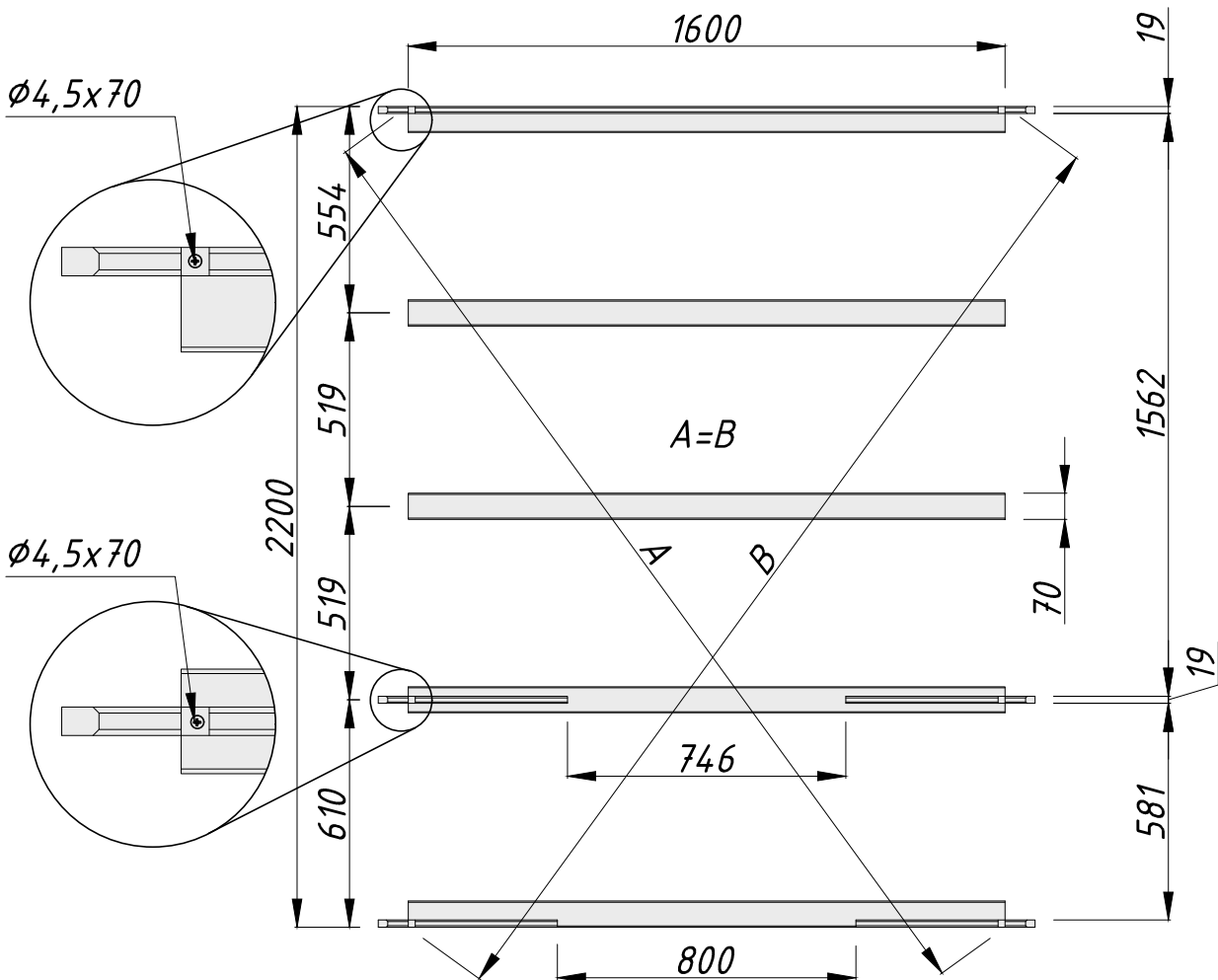
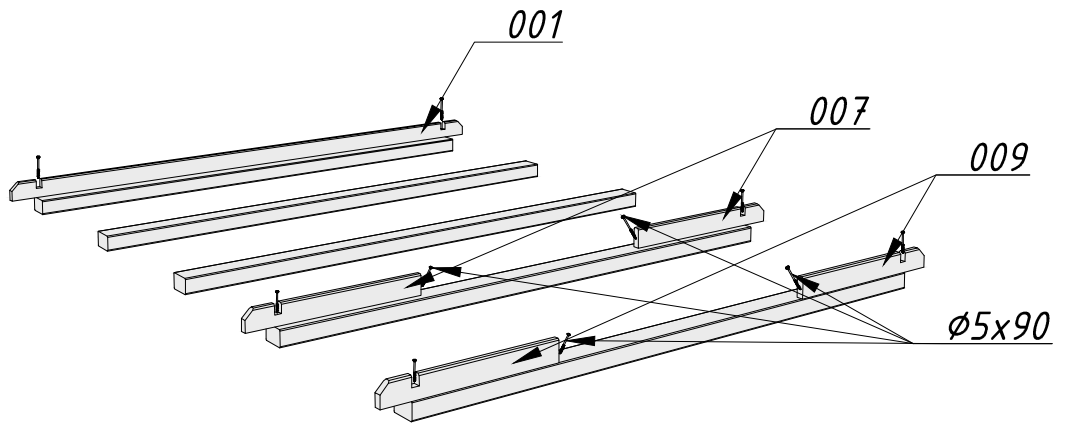

- 002 -5pcs
- 008 -6pcs
- 010 -4pcs
- 011 -2pcs
- 012 -2pcs
- 013 -2pcs
- 014 -2pcs
- 015 -2pcs
-  -4pcs
- $\phi 4 \times 16$ -16pcs

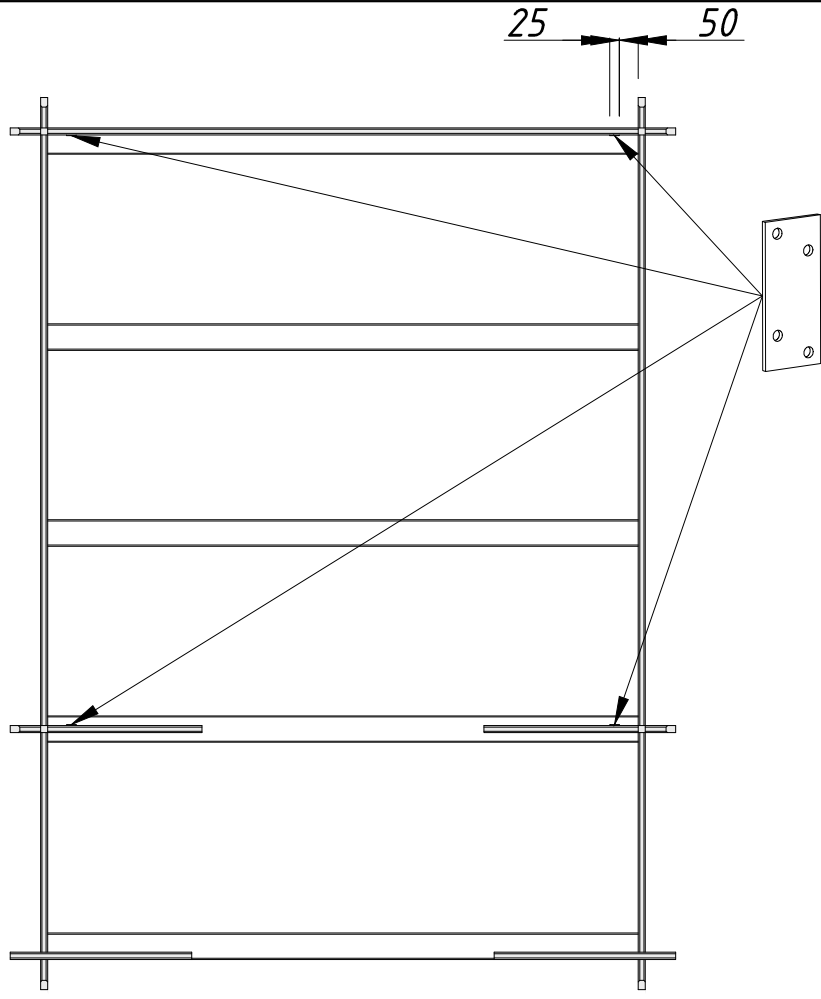
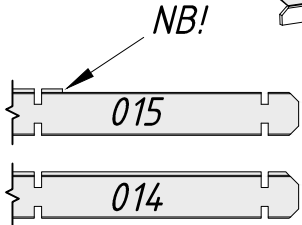
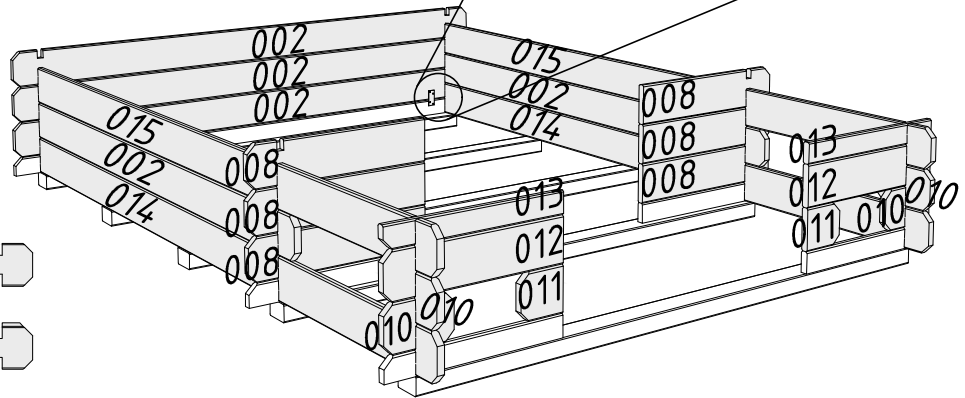
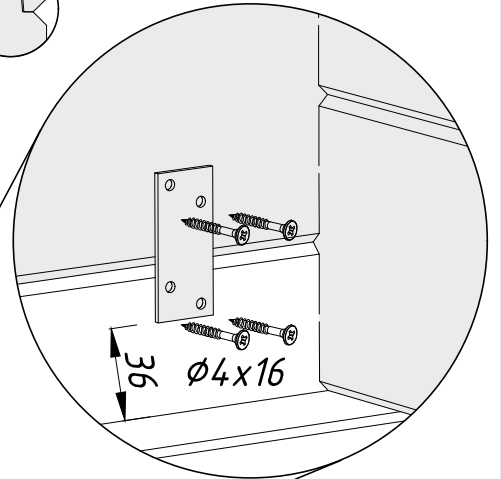
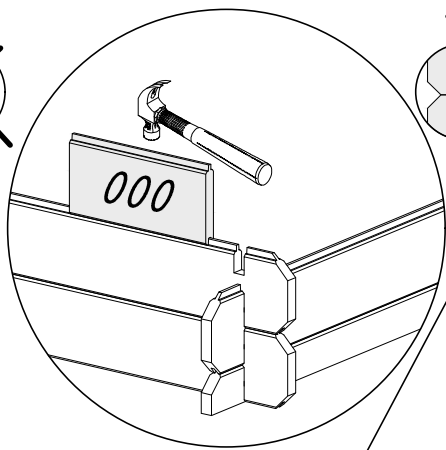
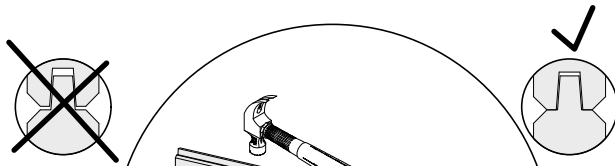

FB1-1 -18pcs
TB3-1 -16pcs
Ø2,2x50 → -110pcs

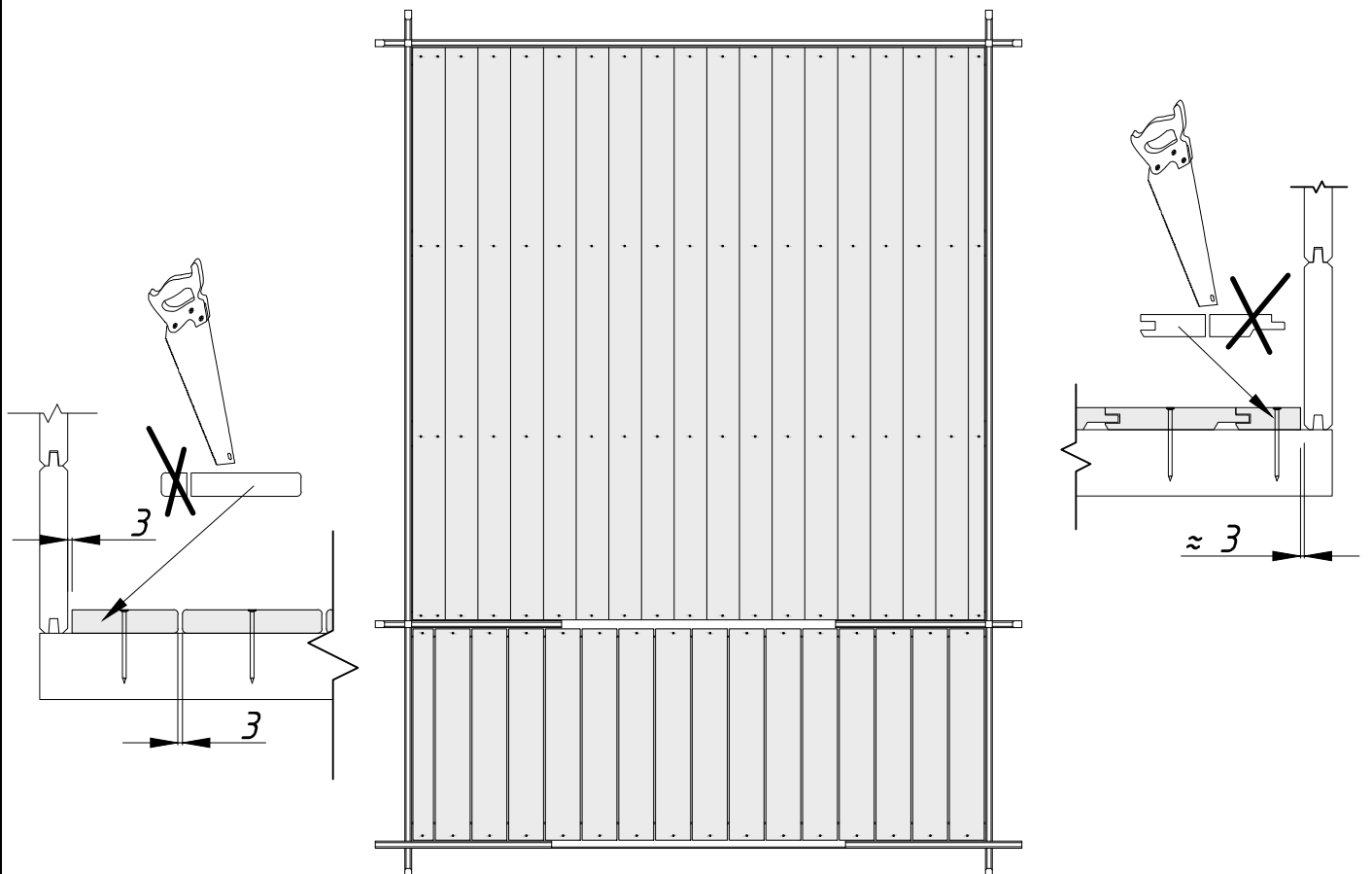
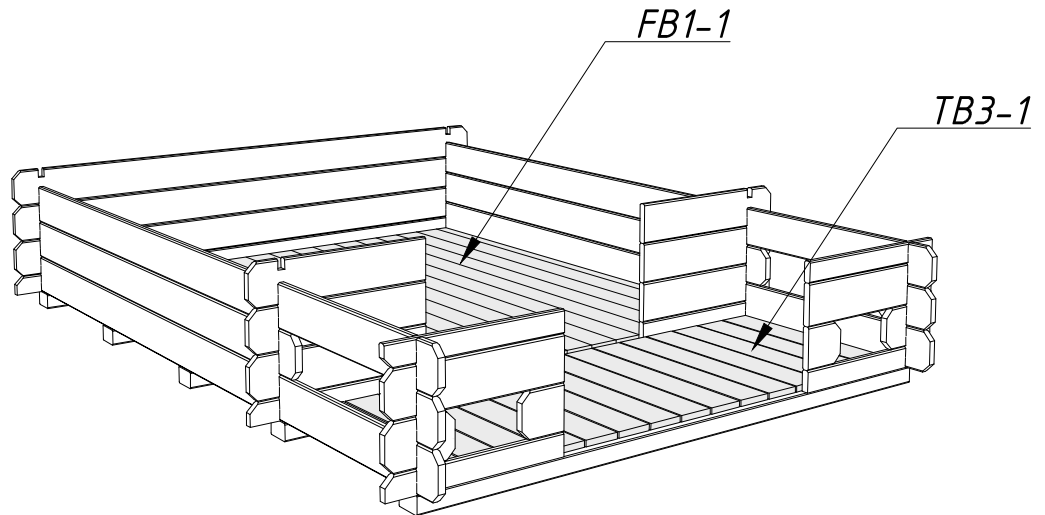

- FIB2-1 -4pcs
- Sla20-1 -1pcs
- Sla20-2 -1pcs
- ∅3x30 -21pcs
- ∅3,5x35 -6pcs

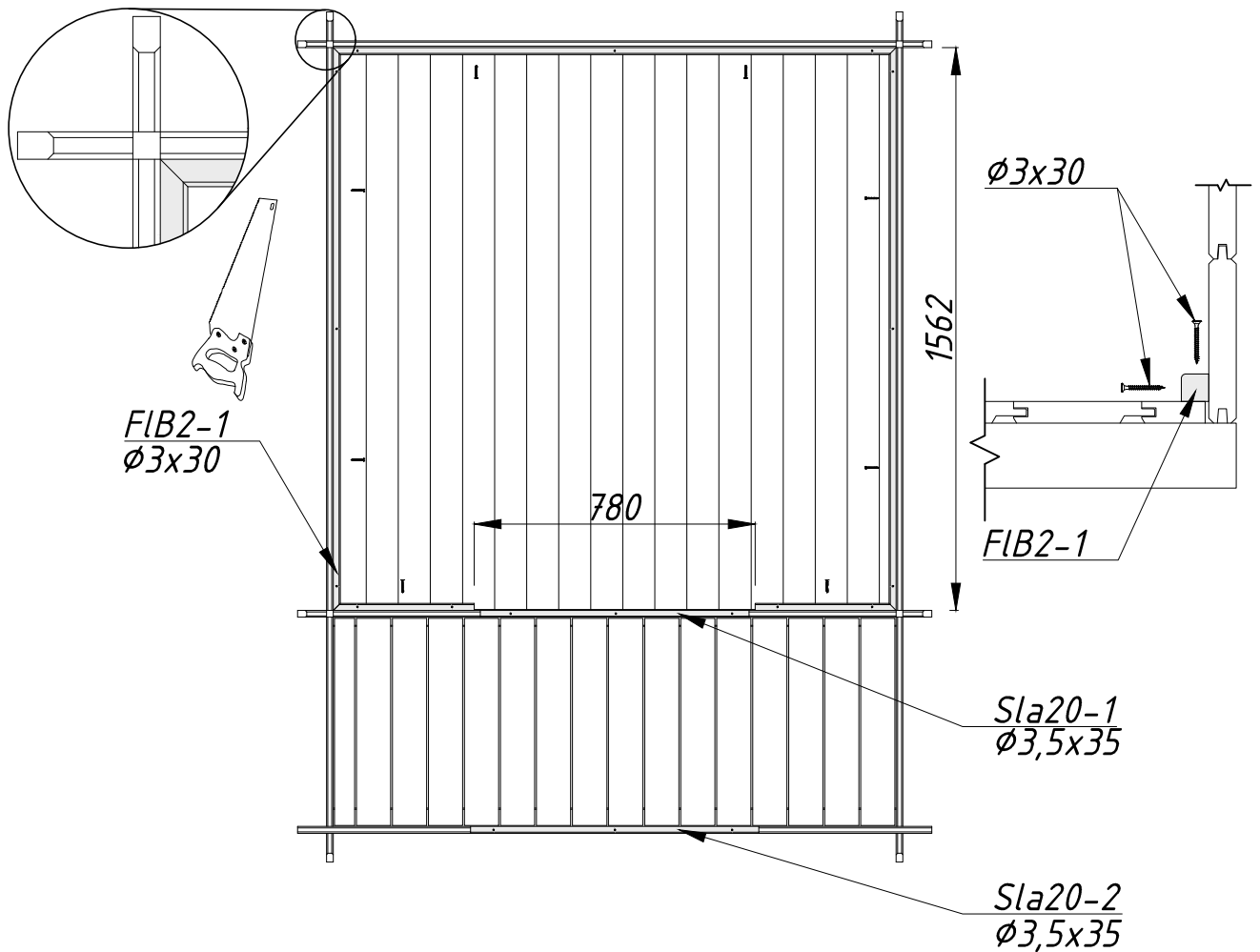
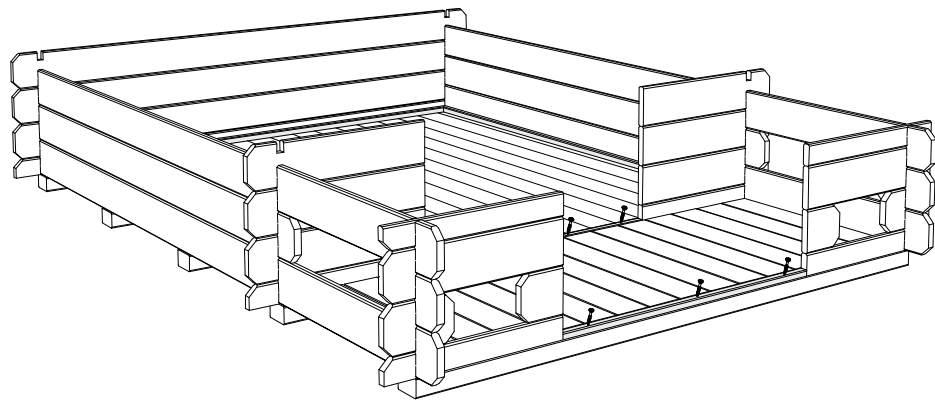

002
008
016

-15pcs
-12pcs
-6pcs

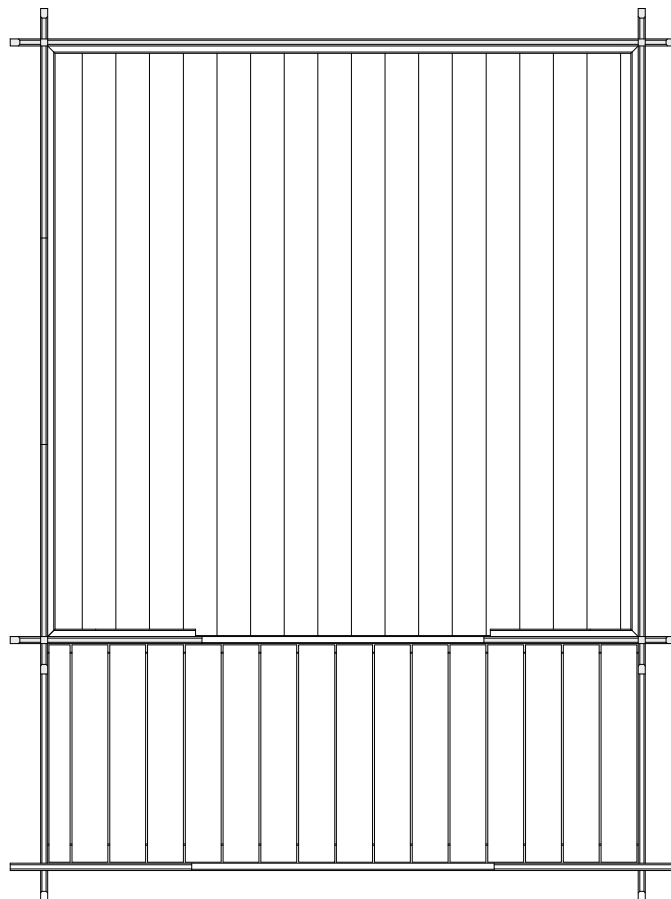
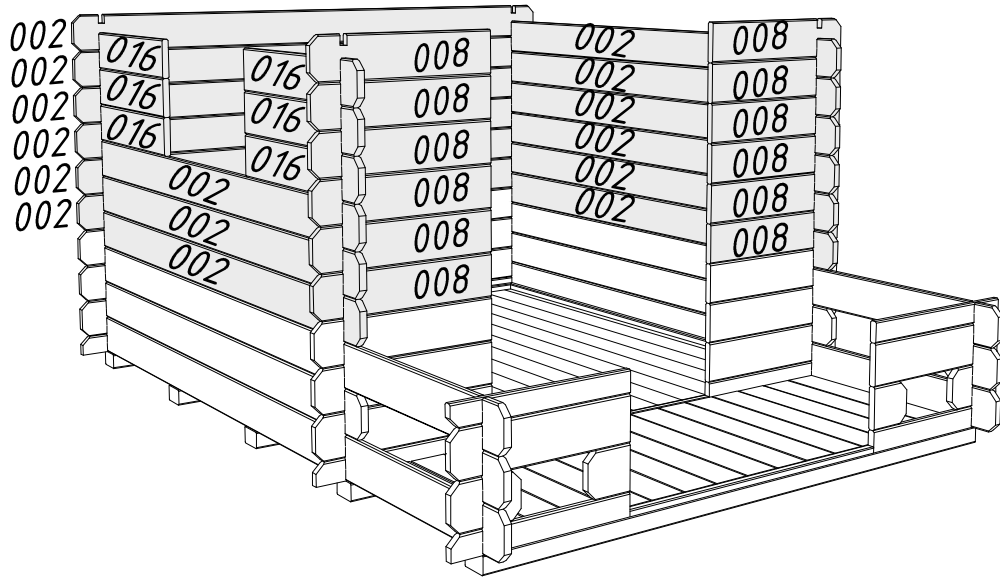
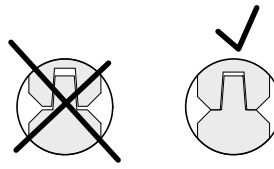

A19-3
 U19-8R

 Ø3x20
 Ø4,5x50

-1pcs
 -1pcs
 -1pcs
 -8pcs
 -2pcs

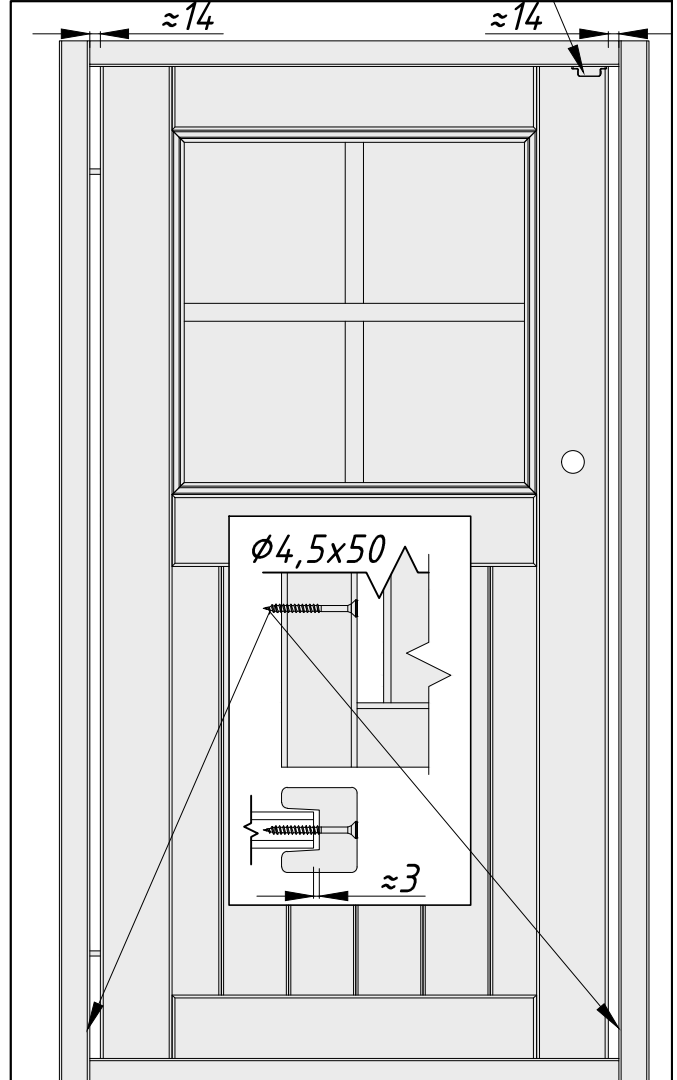
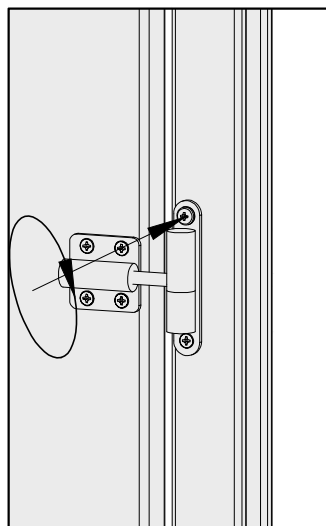
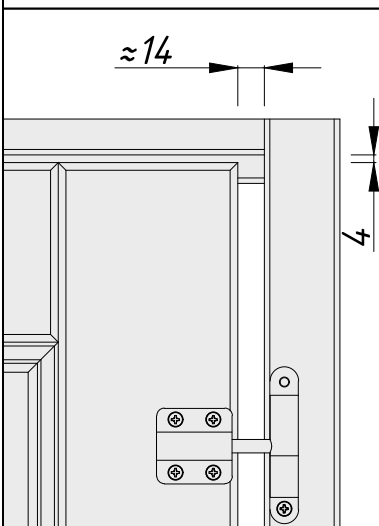
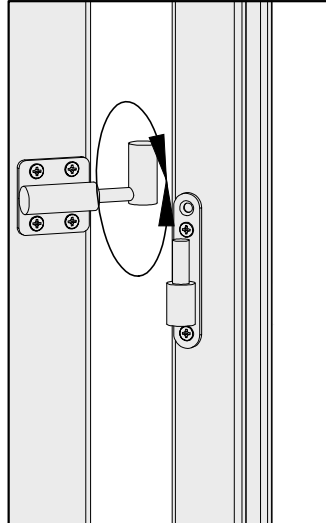
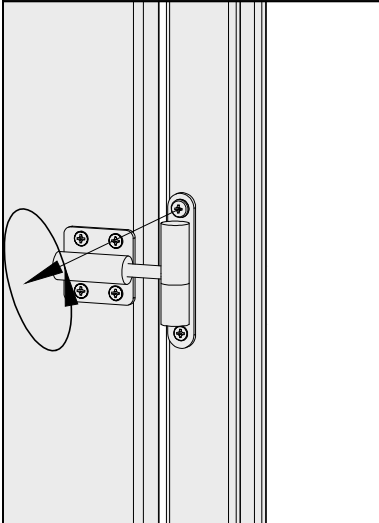
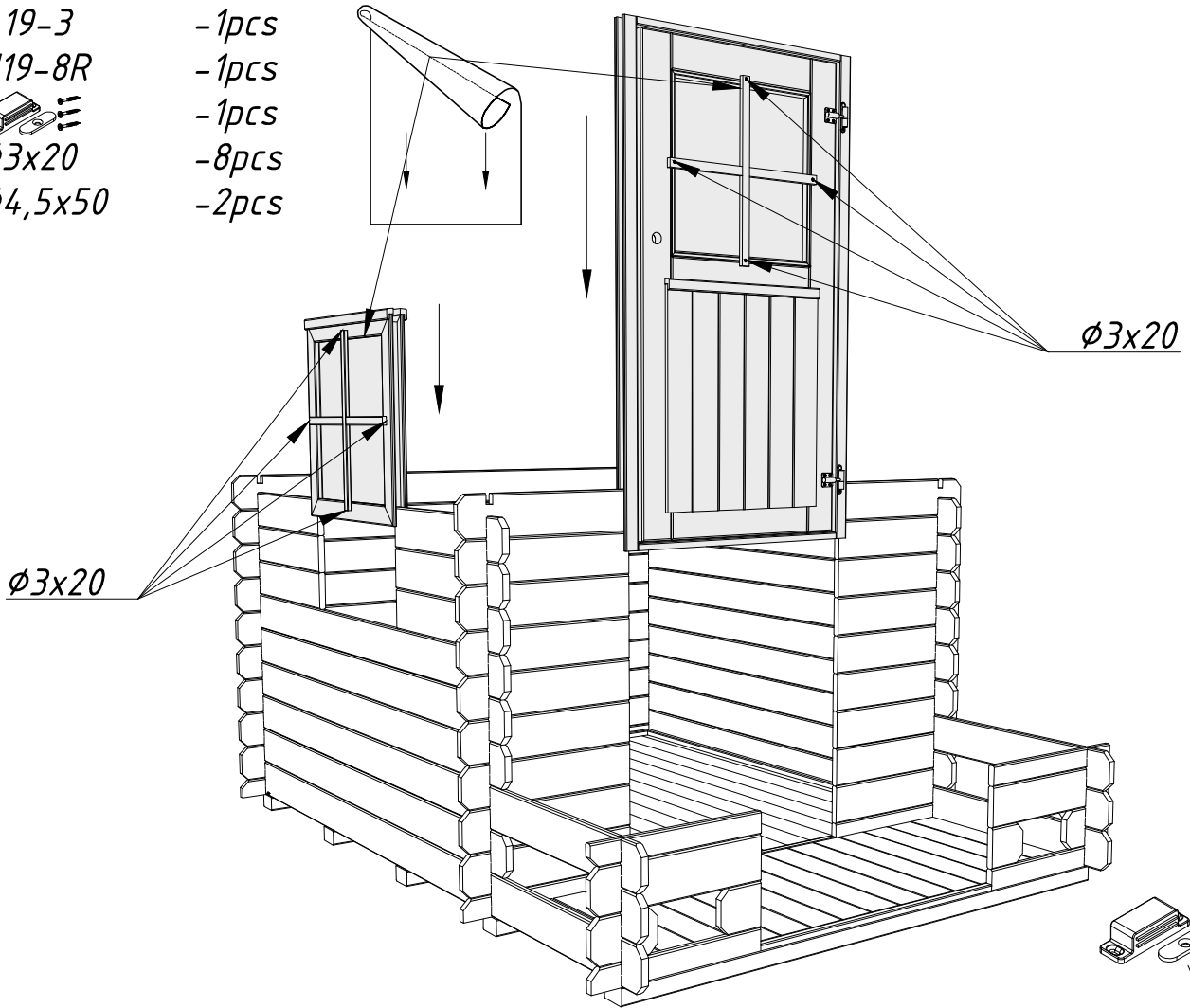

- 002 -5pcs
- 008 -6pcs
- 016 -4pcs
- 017 -2pcs
- 018 -1pcs
- 019 -1pcs
- SiS6-1 -2pcs
- Ø3x30 -8pcs

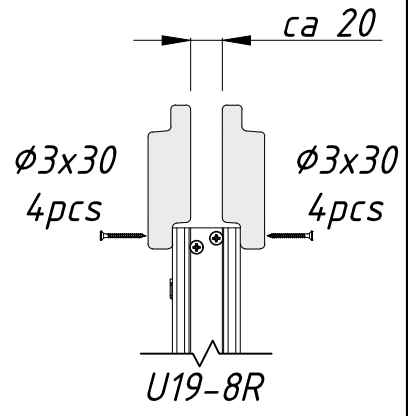
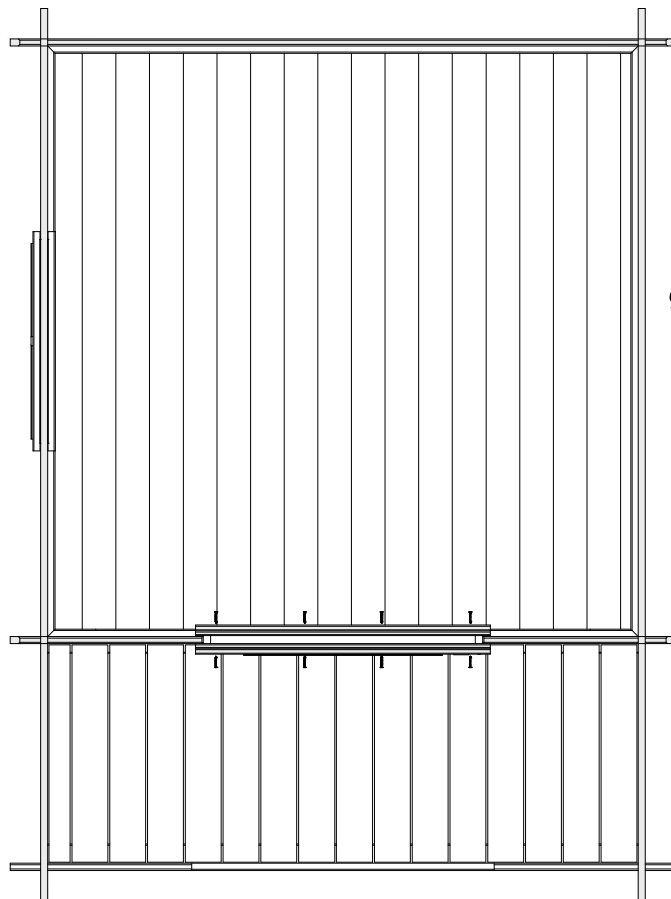
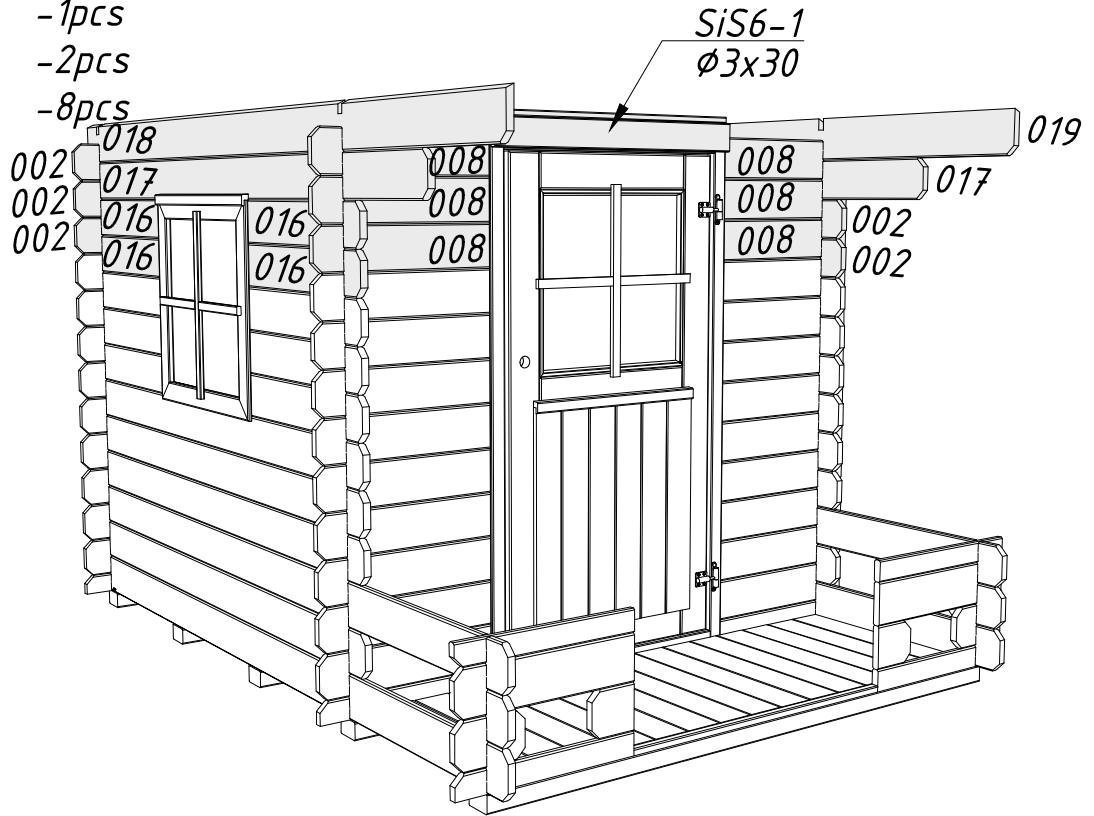
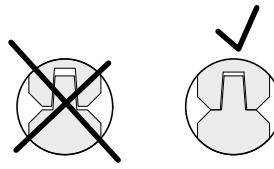

W1-1 -1pcs
W2-1 -1pcs
Ø4,5x70 -4pcs

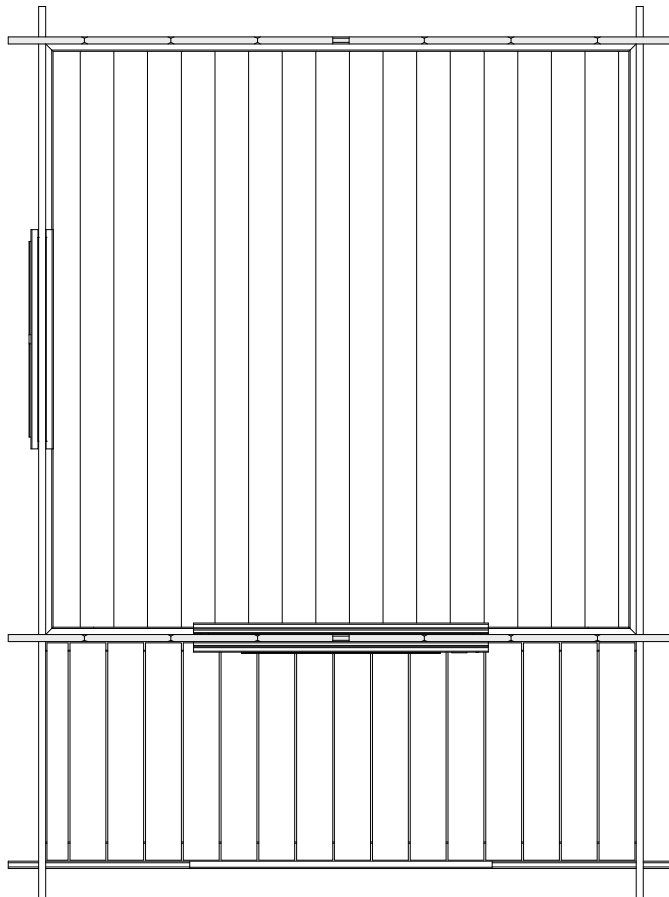
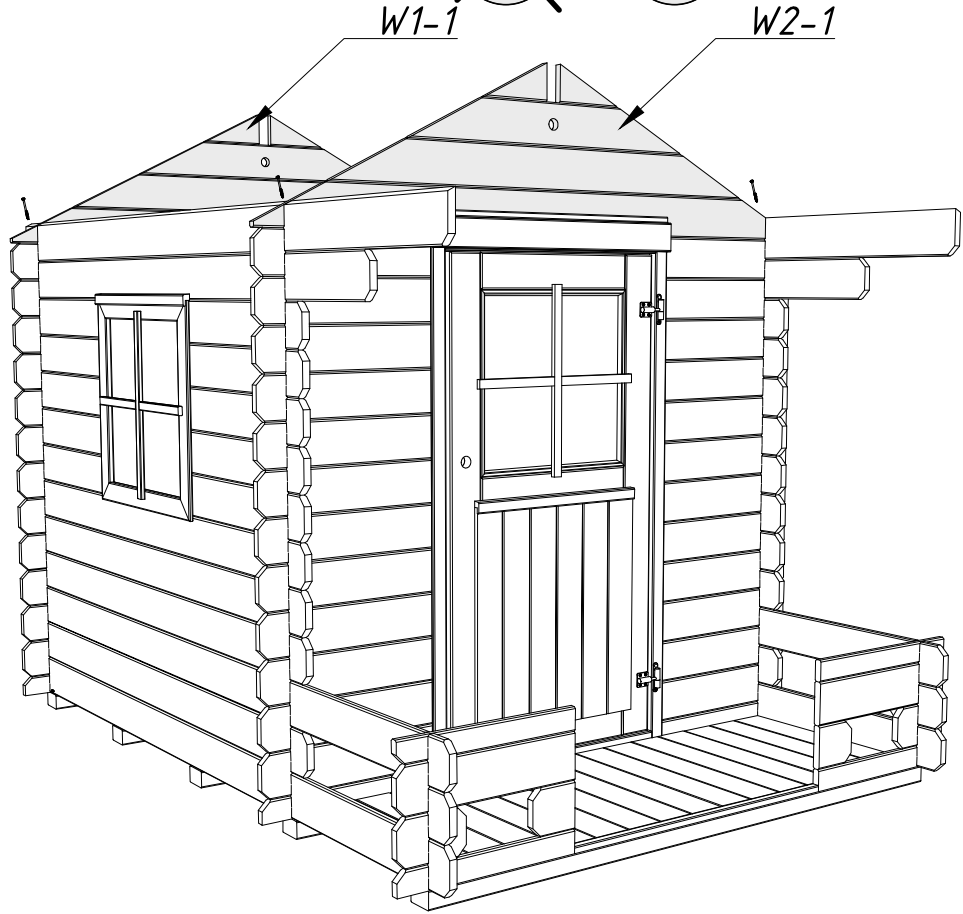
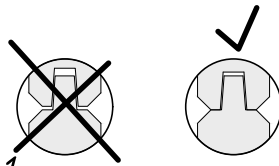

- SP1 -4pcs
- SP2 -4pcs
- UP1 -2pcs
- PR1 -1pcs
- StB1-1 -4pcs
-  -8pcs
- Ø3,5x35 -40pcs
- Ø4,5x70 -4pcs

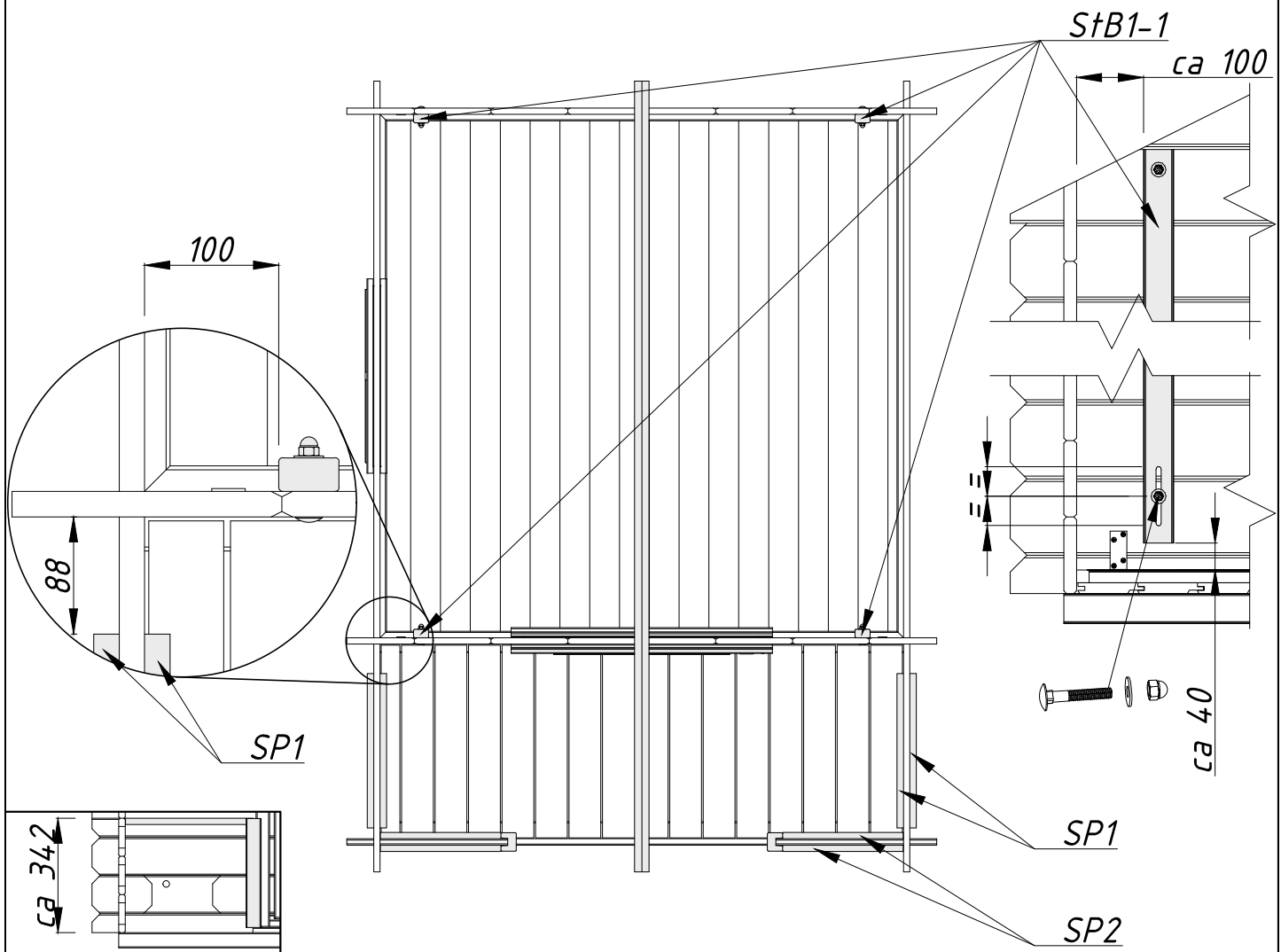
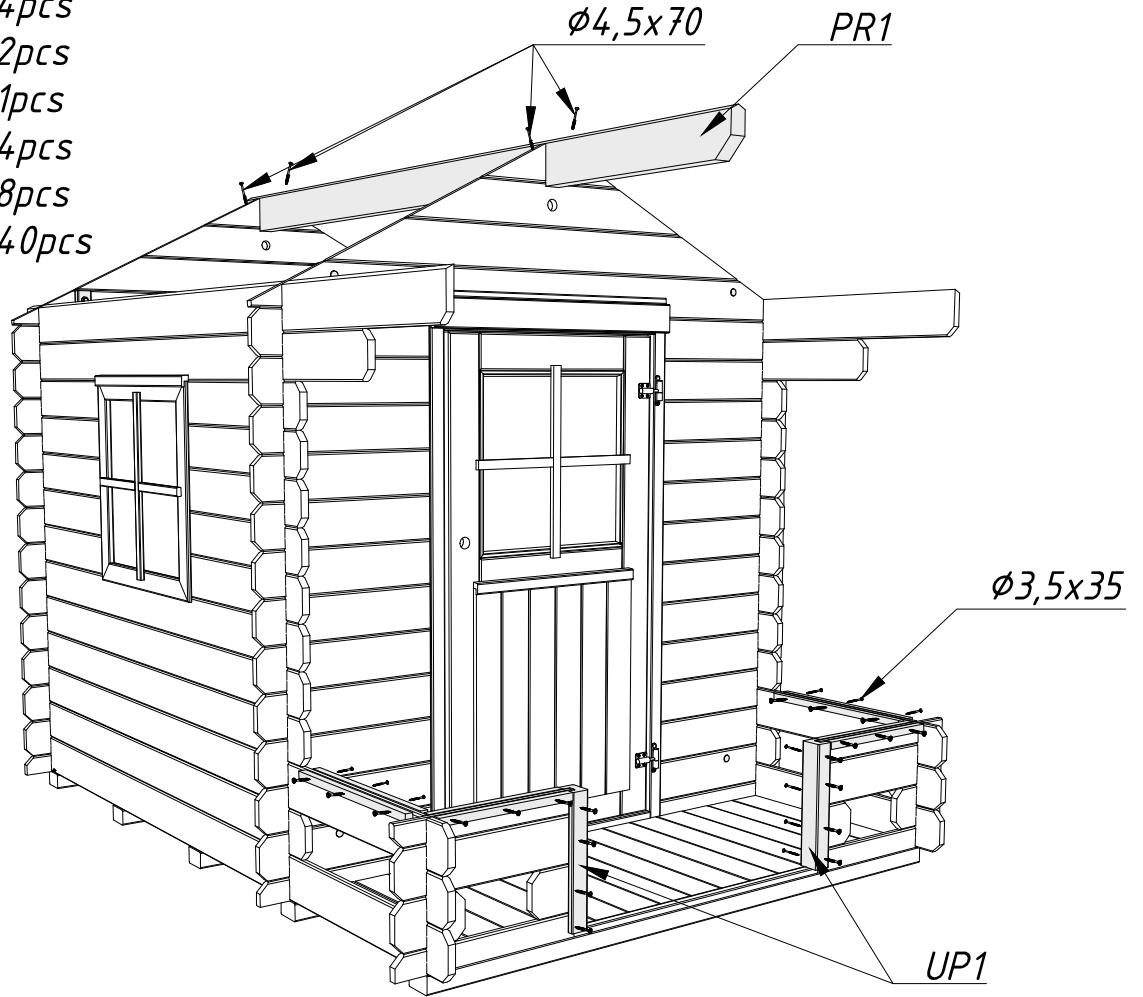

- RB1-1 -54pcs
- Rai1 -2pcs
- Rai2 -2pcs
- Ø2,2x50 -130pcs
- Ø4,5x70 -12pcs

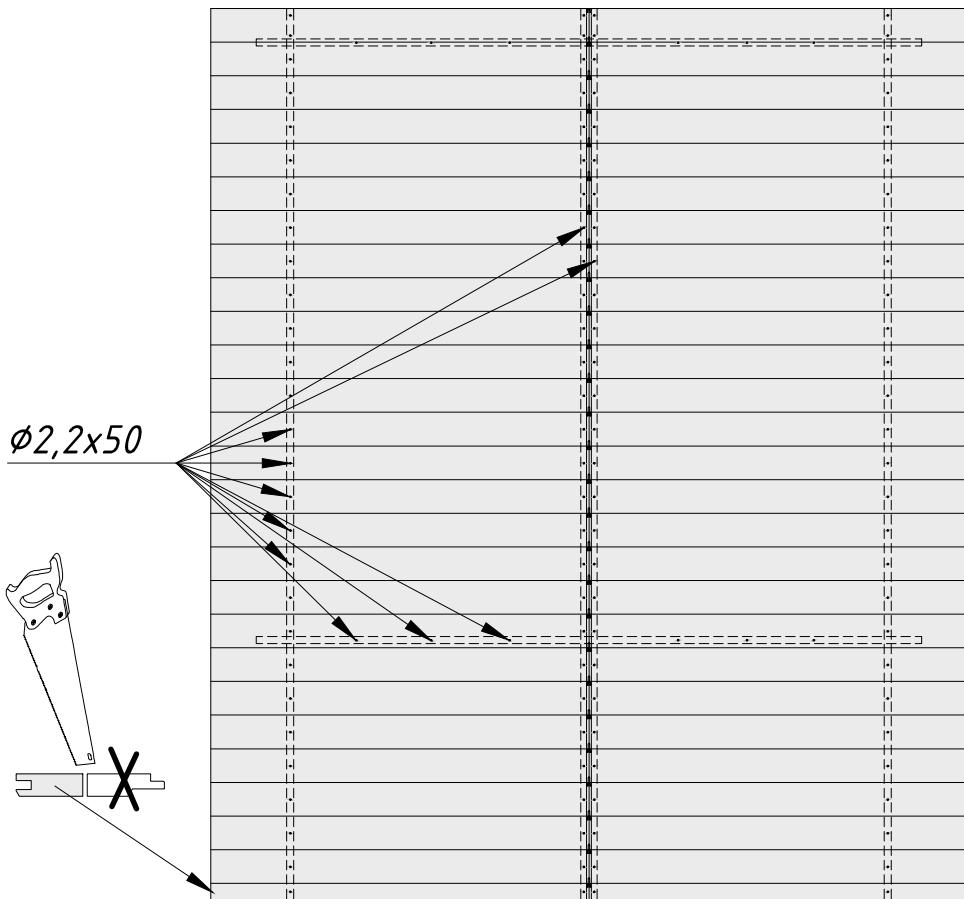
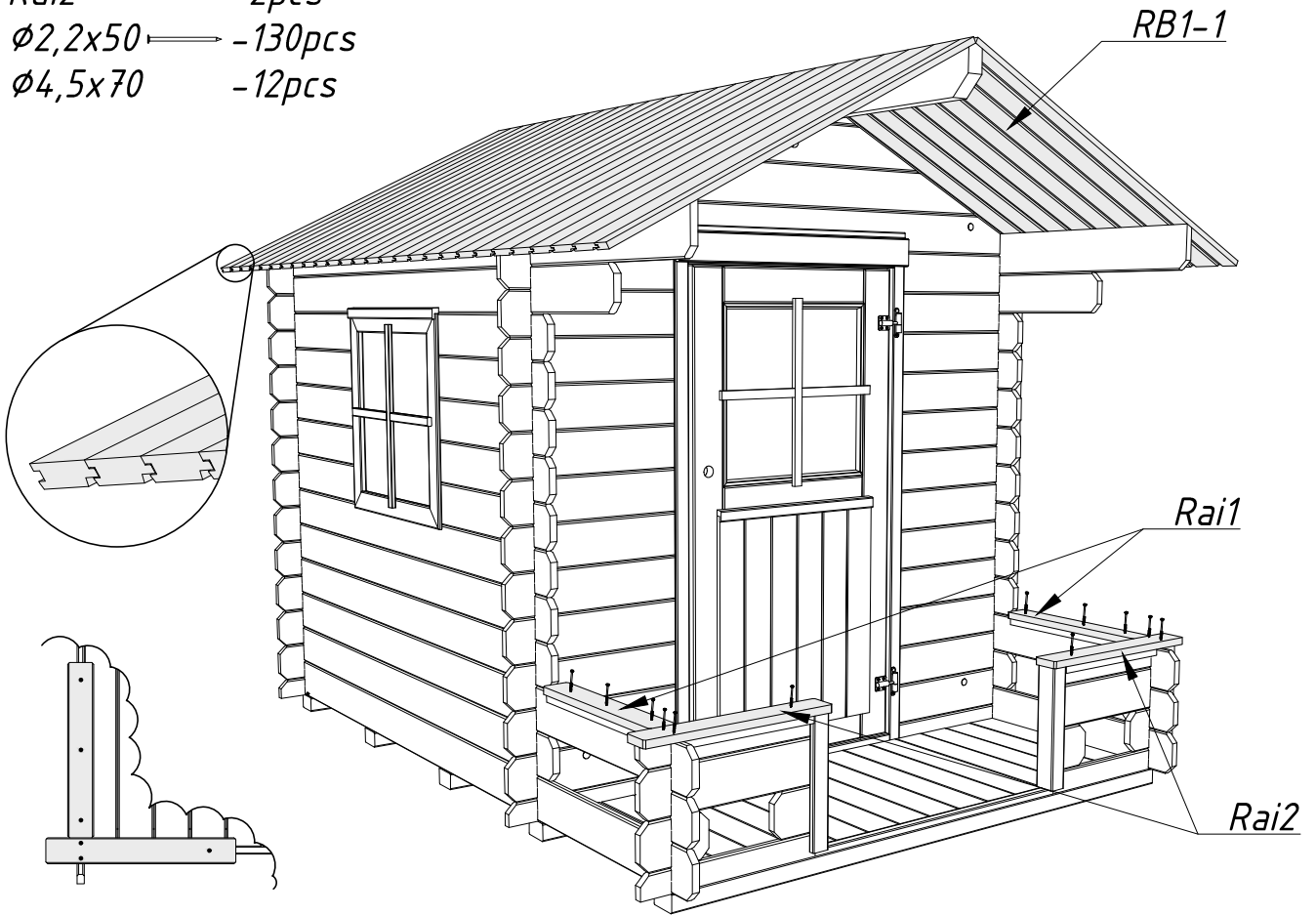

FaB9-1 -4pcs
 RE1-1 -2pcs
 Ø3x30 -18pcs
 Ø4,5x50 -16pcs

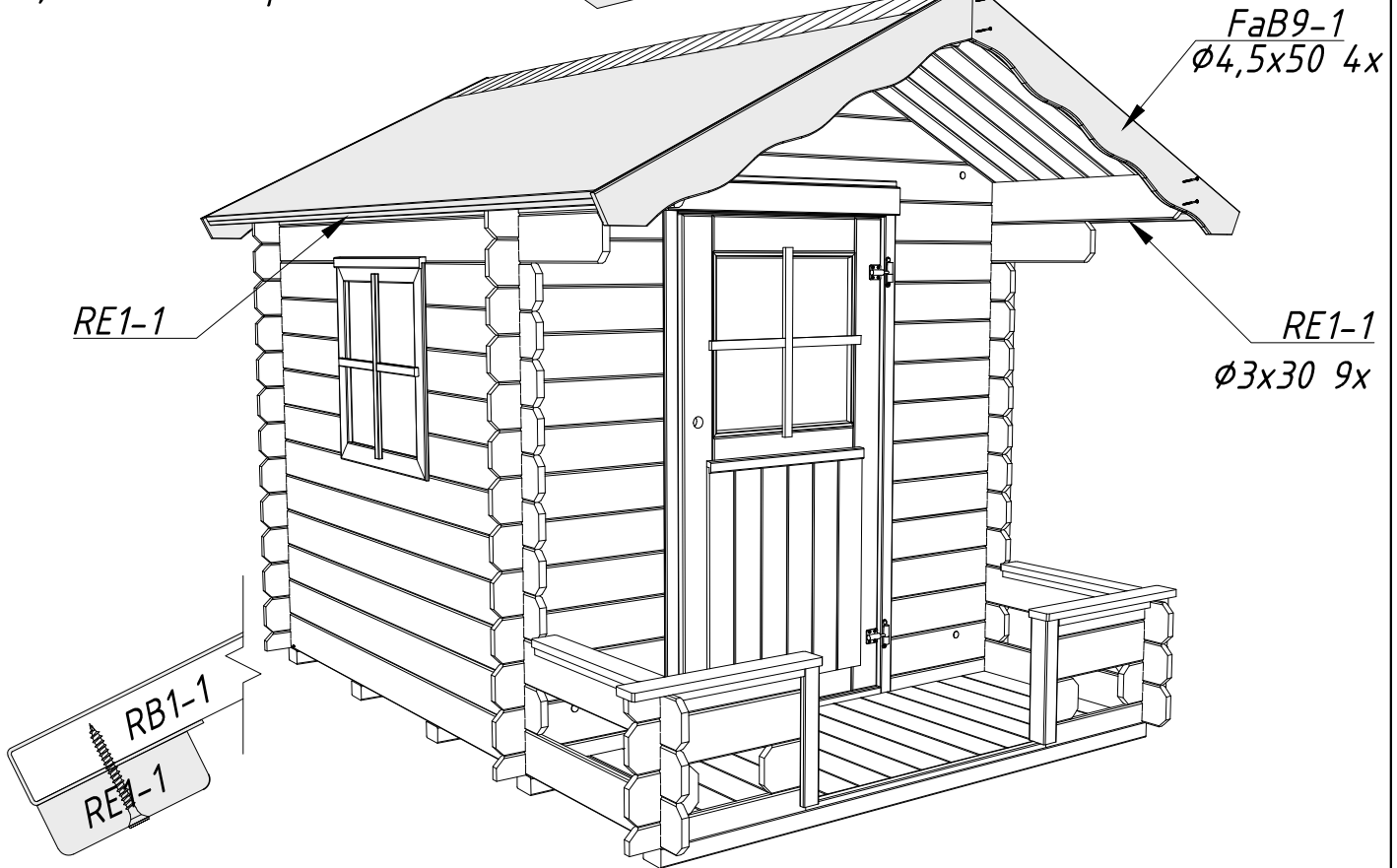

DE - Dachpappe nicht im Lieferumfang!

EN - Roofing felt not included!

ES - Material de cubierta no incluido!

FR - Toiture se sentait pas inclus!

IT - Copertura non si sentiva incluso!

NO - Takdekke ikke inkludert!

SW - Takpapp ingår ej!

FI - Kattohuopa ei sisälly pakettiin!

ET - Katusekattematerjal ei sisaldu komplektis!

NL - Dakvilt is niet inbegrepen in het pakket!

LV - Jumta pape komplektā nav iekļauta!

LT - Stogo tolis į komplektą neįtrauktas!

PL - Okładzina dachowa nie wchodzi w skład zestawu!

DK - Tagmateriale medfølger ikke!

CZ - Krytinová rohož není zahrnuta v sadě!

PT - Não incluídos no kit: material para a cobertura de teto!

Dia-1 -2pcs
WB1-1 -4pcs
Ø3x30 -4pcs
Ø4,5x50 -12pcs

Dia-1 13

Ø3x30 2x

WB1-1 3x
Ø4,5x50

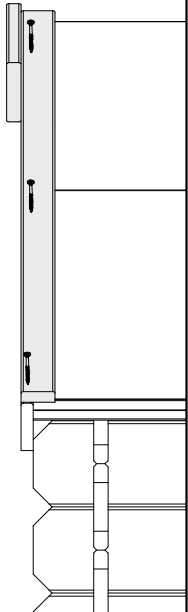
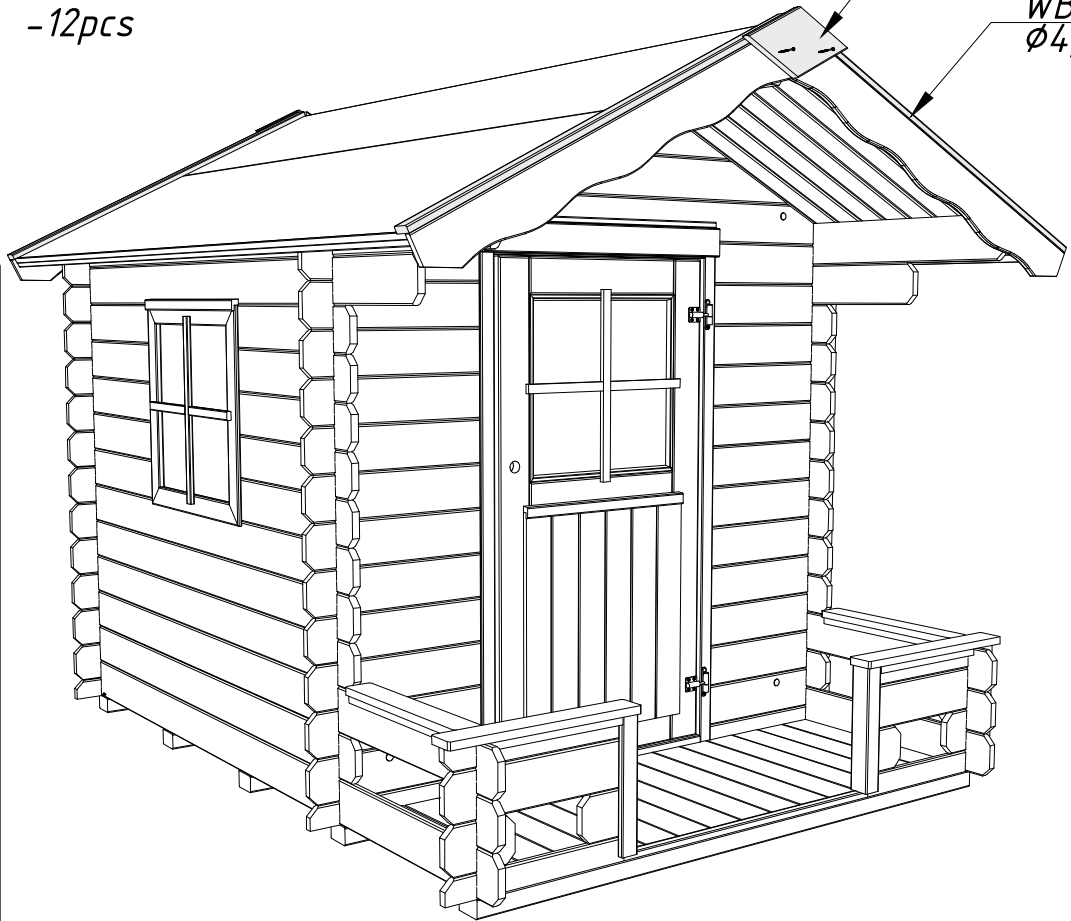

WB1-1

Dia-1

WB1-1

